



DEMO

This DEMO contains only a few pages of the entire manual/product.

Not all Bookmarks work on the Demo, but they do on the full version.

Features:

- Searchable text
- Printable pages
- Bookmarked for easy navigation
- High Resolution images
- Zoom to see exact details
- Money back Guarantee
- Transfer to USB flash drive support

1976 Truck Wiring Diagrams



Models Covered Include:

Bronco
Courier
Econoline
P-Series
F-100-350 Series
F-500-750 Series

B-500-750 Series
C-Series
W-Series
L-Series - Line Haul
L-Series - City Delivery

Buy Now



*Complete Set of Original OEM
Ford Motor Company Wiring Diagrams*



Ford Parts and Service Division
Training and Publications Department



Copyright © 2015, Forel Publishing Company, LLC, Woodbridge, Virginia

All Rights Reserved. No part of this book may be used or reproduced in any manner whatsoever without written permission of Forel Publishing Company, LLC. For information write to Forel Publishing Company, LLC, 3999 Peregrine Ridge Ct., Woodbridge, VA 22192

1976 Ford Truck Wiring Diagrams

EAN: 978-1-60371-209-5

ISBN: 1-60371-209-7

Forel Publishing Company, LLC

3999 Peregrine Ridge Ct.

Woodbridge, VA 22192

Email address: sales@ForelPublishing.com

Website: www.ForelPublishing.com



License #2013225

This publication contains material that is reproduced and distributed under a license from Ford Motor Company. No further reproduction or distribution of the Ford Motor Company material is allowed without the express written permission of Ford Motor Company.

Note from the Publisher

This product was created from the original Ford Motor Company's publication. Every effort has been made to use the original scanned images, however, due to the condition of the material; some pages have been modified to remove imperfections.

Disclaimer

Although every effort was made to ensure the accuracy of this book, no representations or warranties of any kind are made concerning the accuracy, completeness or suitability of the information, either expressed or implied. As a result, the information contained within this book should be used as general information only. The author and Forel Publishing Company, LLC shall have neither liability nor responsibility to any person or entity with respect to any loss or damage caused, or alleged to be caused, directly or indirectly by the information contained in this book. Further, the publisher and author are not engaged in rendering legal or other professional services. If legal, mechanical, electrical, or other expert assistance is required, the services of a competent professional should be sought.

How to Print Wiring Diagram Pages

Many of the original Ford wiring manuals were created in a very large format (11x17, 17x24, and 17x36) making it difficult to print on a standard home printer. Some printers will print only a portion of the entire page, while others will shrink the page into an unreadable format. However, Adobe Reader has the ability to print sections (known as Tiles) of the page onto standard 8.5x11 paper. Please use the steps below to print these wiring diagrams.



You can print a large format document, such as these wiring diagrams, by splitting the page across multiple sheets of paper (called "tiling"). The tiling option calculates how many sheets of paper are needed. You can adjust the size of the original to best fit the paper and specify how much each "tile" overlaps. You can then piece together the tiles.

1. Choose File > Print.
2. From the Page Scaling pop-up menu, select one of the following options:
Tile Large Pages Tile only the pages that are larger than the paper.
Tile All Pages Tile all the pages in the PDF file.

Note: If the tile options are not in the menu, make sure that the following options are not selected in the Advanced Print dialog box: Print As Image or, for Acrobat only, Separations or In-RIP Separations. Also check your version of Reader. Reader 9 does not support tiling.

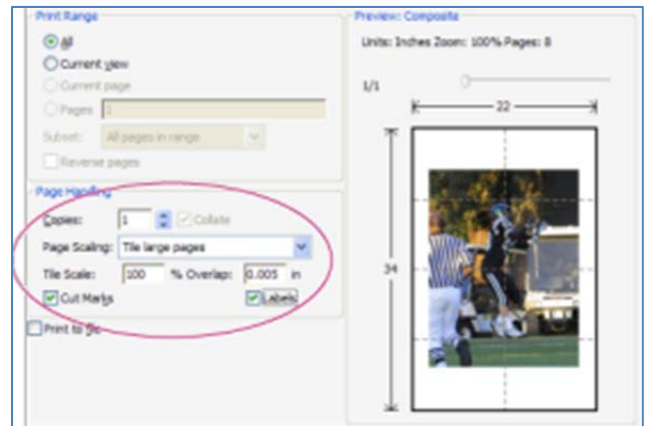

3. Set the following options as needed:
Tile Scale Scales the pages by the amount you specify.
Overlap Determines the amount each tile overlaps adjacent tiles.
Cut Marks Adds guide marks to each page to help you trim the overlap.
Labels Adds the filename and page number on each "tile".

4. Click OK or Print.

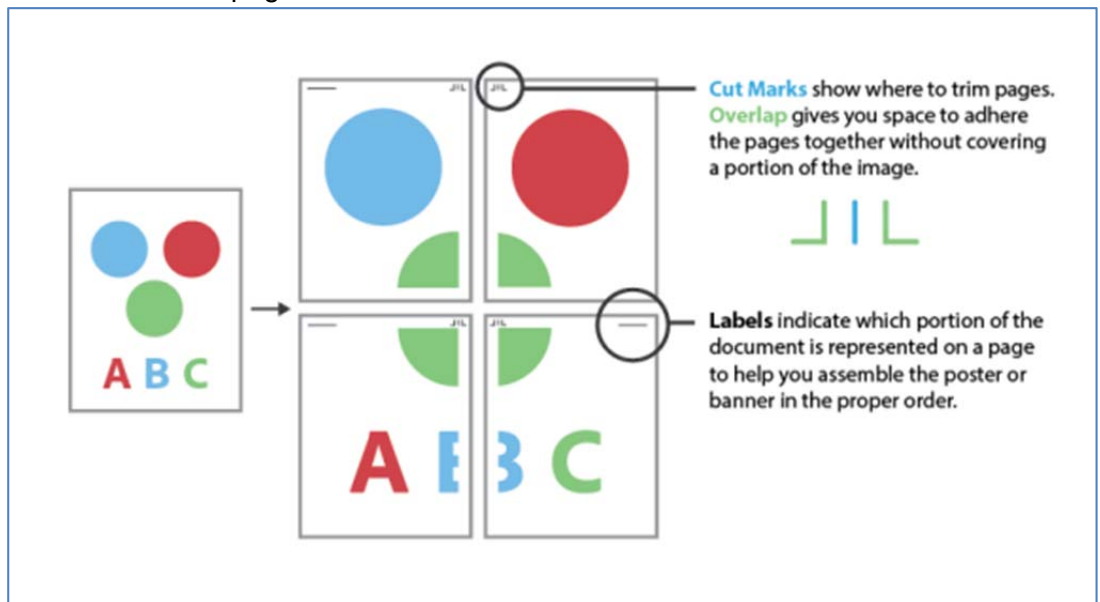

How to Print a Portion of a Wiring Diagram



You can print a portion of a page in a PDF. The Snapshot Tool lets you select just the area you want to print. The area can be text, graphics, or both. You can print the selected area full size or resize it to fit the paper.

1. Open the PDF in Adobe Reader or Adobe Acrobat.

2. (Acrobat X/Reader X) Choose Edit > Take A Snapshot.
(Acrobat 9/Reader 9) Choose Tools > Select & Zoom > Snapshot Tool.

3. Drag a rectangle around the area you want to print.

4. Choose File > Print.

5. Make sure that the **Selected Graphic** option is selected in the Print Range area of the Print dialog box.

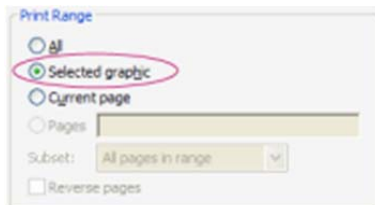

6. (Optional) To enlarge the selected text or graphic to fit the sheet of paper, choose Fit To Printable Area from the Page Scaling pop-up menu.

Note: Enlarging the area reduces the printed resolution.

7. Click OK or Print.

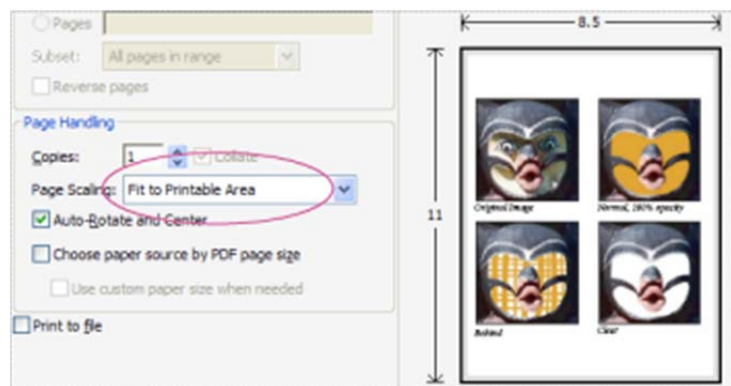

How to Print a Portion of a Wiring Diagram

Print Current View

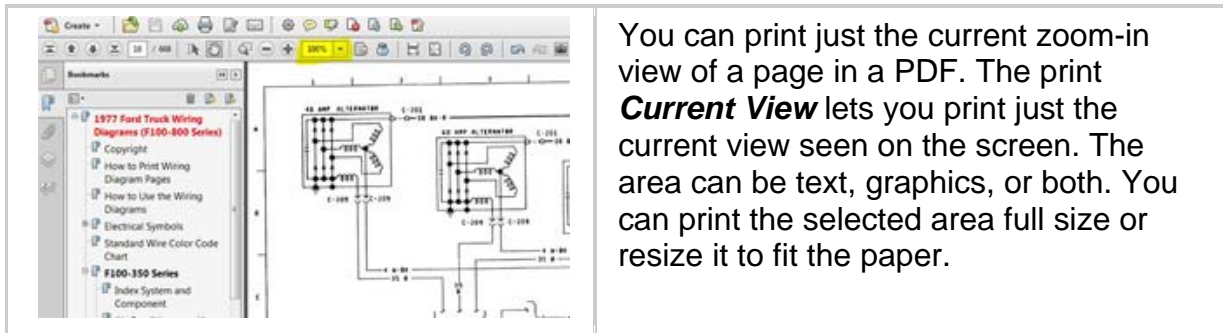

1. Open the PDF in Adobe Reader or Adobe Acrobat.
2. Zoom into the portion of the diagram you want to print.

3. Choose File > Print.

4. Make sure the **Current View** option is selected in the Pages to Print area of the Print dialog box.

Note – To select Current view, you may need to click the “More Options” dropdown.

5. (Optional) To enlarge the selected text or graphic to fit the sheet of paper, choose Fit To Printable Area from the Page Scaling pop-up menu.

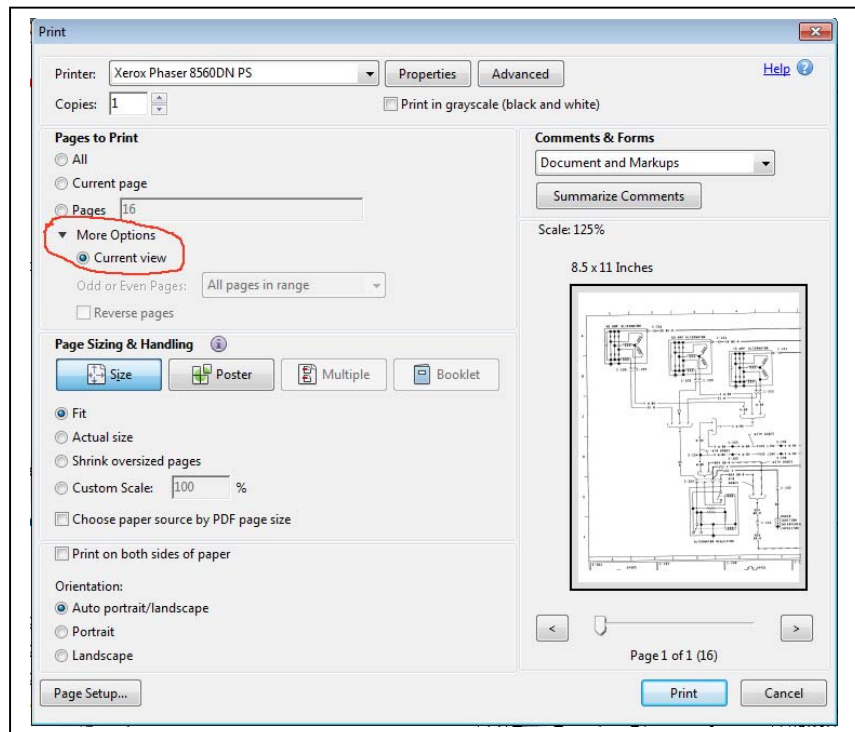

Note: Enlarging the area reduces the printed resolution.

6. Click OK or Print.

1976 TRUCK WIRING DIAGRAMS

- Bronco
- Courier
- Econoline
- P-Series
- F-100-350 Series
- F-500-750 Series
- B-500-750 Series
- C-Series
- W-Series
- L-Series - Line Haul
- L-Series - City Delivery

“Our goal: No unhappy owners.”



Ford Parts and Service Division
Training and Publications Department

The illustrations contained in this book were in effect at the time the book was approved for printing. Ford Motor Companies, whose policy is one of continuous improvement, reserves the right to discontinue models at any time, or to change specifications or design, without notice and without incurring obligations.

HOW TO USE THE WIRING DIAGRAMS

INDEX

An INDEX is provided behind the divider for each truck series. The index page contains an alphabetically arranged list of systems and components and a bulb usage list. The index lists the location of the components on the drawing. Examples of the two types of index references are shown:

- To locate an electrical part at D-49, find the location number 49 at the top of the illustration. Then, find the letter D on the side of the illustration. Follow the number and the letter until the lines intersect. The part will be within an inch or two of the intersection.
- To locate an electrical part at PG3-D10, turn to page 3 as indicated in the lower right corner of the sheet. Then, find the number 10 at the top of the illustration and the letter D on the side of the illustration. Follow the number and the letter until the lines intersect. The part will be within an inch or two of the intersecting lines.

BASIC INFORMATION

Generally, the power supply for all components on this drawing comes from the top of the page and over to the battery at the left.

The ground for each component is always toward the bottom of the drawing that are explained as follows:

- Ground symbols are shown in Figure 1. A ground wire connected away from the component is identified by a code G1 or G2, etc. The location of the remote ground is listed in the GROUND CODES chart and the bottom of the page.

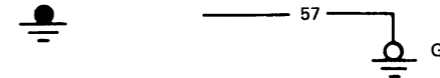

Fig. 1 – Ground Symbols

- Wire color code is shown in Figure 2. Wire color codes (by color) are listed on page 4.



Fig. 2 – Wire Color Code

If a vehicle specific wire color in a connector does not match the diagram shown, it can usually be identified by comparing the other colors shown at the wire connectors. Specific wire color deviations in the manufacturing of a wire harness are usually for a short duration.

- Harness number is shown in Figure 3. The 5 or 6 digit number near the wire indicates the wire harness basic part number.

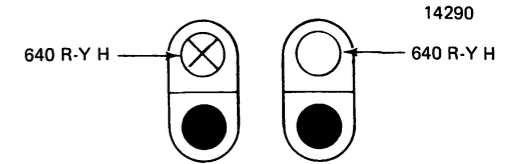

Fig. 3 – Harness Number

- Wire connector identification code is shown in Figure 4. The key for the connector codes is located at the bottom of the wiring diagram.

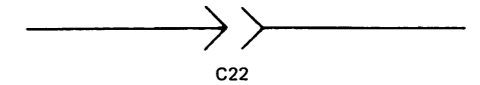

Fig. 4 – Wire Connector Code

- Male connector symbol is illustrated in Figure 5. The symbol used for the diagram and chart is shown.

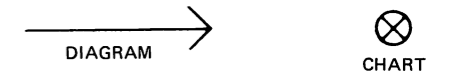

Fig. 5 – Male Connector Codes

- Female connector symbol is shown in Figure 6.



Fig. 6 – Female Connector Codes

- Splice is shown in Figure 7. A splice is a common point where two wires are joined together. Location of splice is at bottom of schematic page.

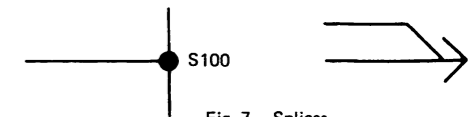
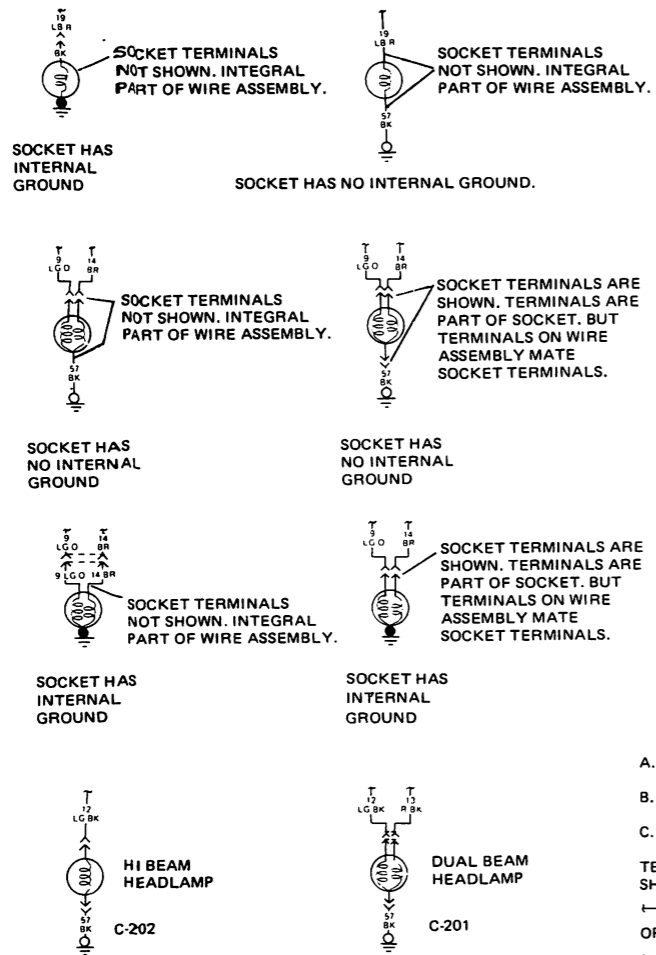

Fig. 7 – Splices

- Heavy lines for the wires indicate a direct to battery feed.
- Heavy dashed lines indicate an ignition switch accessory feed.

Electrical symbols used in the schematics are illustrated and described on the next page.

SOCKETS



HEADLAMPS DO NOT HAVE SOCKETS, AND ARE SHOWN AS ABOVE.

VARIOUS MOTOR TYPES

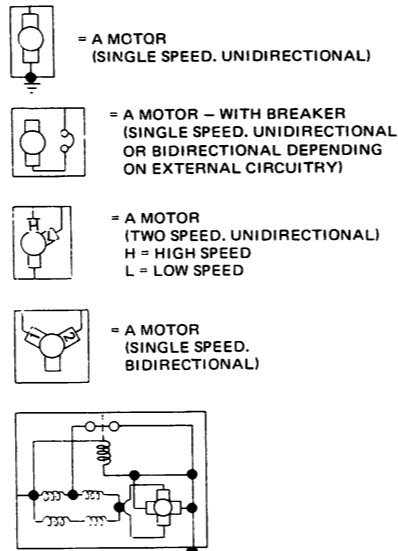

TERMINALS AND CONNECTORS

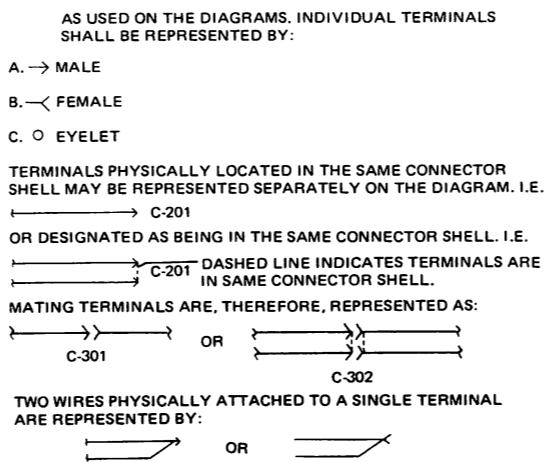

TYPICAL DISTRIBUTORS

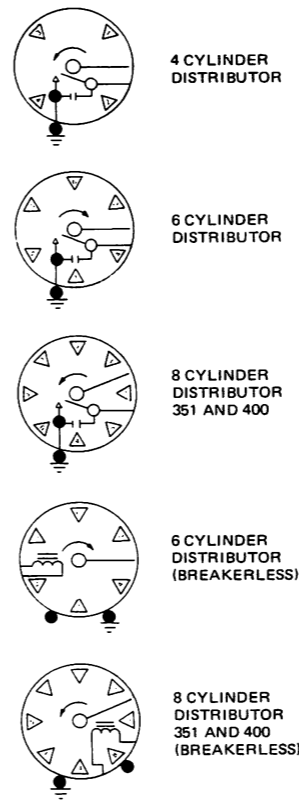

WIRE TYPES

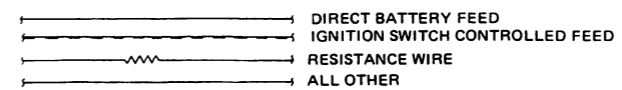

COMPONENT TERMINATIONS

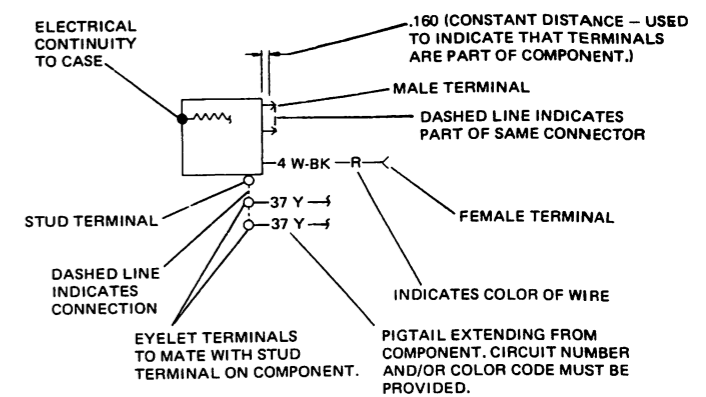

GROUND INDICATIONS

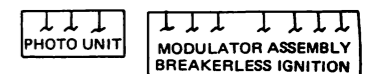
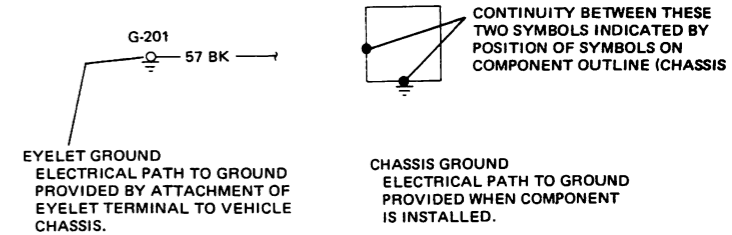

TYPICAL EXAMPLES OF COMPONENTS WITH UNDEFINED INTERNALS.

USED IN CASES WHERE COMPONENTS ARE NOT SERVICEABLE AND ARE CONSIDERED REPLACEABLE ONLY, AND INTERNAL CIRCUITRY IS NOT CONSIDERED NECESSARY FOR CLEAR UNDERSTANDING OF ASSOCIATED WIRING AND COMPONENTS.

STANDARD WIRE COLOR CODE CHART

CIRCUIT	DESCRIPTION	COLOR	CIRCUIT	DESCRIPTION	COLOR
1	HORN SWITCH TO HORN RELAY	BLUE-YELLOW STRIPE	69	COIL TERM. IGN. SW. TO FUEL SOLENOID	RED-GREEN STRIPE
2	TURN SIGNAL SW. TO RH FRONT TURN SIGNAL LAMP	WHITE-BLUE STRIPE	71	IGNITION SWITCH TO FUSE PANEL	BLACK
3	TURN SIGNAL SWITCH TO LH FRONT TURN SIGNAL LAMP	GREEN-WHITE STRIPE	72	ENGINE ALARM RELAY (OIL PRESSURE) TO IND. LAMP	GREEN
4	ALTERNATOR REG. "S" TERM. TO ALTERNATOR "S" TERM.	WHITE-BLACK STRIPE	73	LOW AIR BUZZER TO LOW AIR BUZZER SWITCH	ORANGE-GREEN STRIPE
6	HORN RELAY TO HORN	YELLOW-GREEN STRIPE	74	RELAY "H" TERMINAL TO LAMP (WATER)	GREEN
8	IGNITION SWITCH TO TURN SIGNAL FLASHER	ORANGE-YELLOW STRIPE	75	STARTING MOTOR RELAY TO SERIES PARALLEL SW. (NO. 1 TERM.)	GREEN-RED STRIPE
10	FUSE PANEL TO STOPLAMP SWITCH	GREEN-RED STRIPE	76	MARKER LAMP FEED (NON TRACTOR) TO AUX. CIRC. BREAKER	BLACK-GREEN STRIPE
11	HEADLAMP SWITCH TO PARKING LAMPS	BLACK-YELLOW STRIPE	78	CIR. BREAKER TO RH & LH MARKER LAMPS	BLUE-YELLOW STRIPE
12	HEADLAMP DIMMER SWITCH TO HIGH BEAMS	GREEN-BLACK STRIPE	79	CONTROL RECTIFIER TO ALT. REG. "IGN." TERM.	GREEN-RED STRIPE
13	HEADLAMP DIMMER SWITCH TO LOW BEAMS	RED-BLACK STRIPE	80	BATTERY TO ENGINE COMPARTMENT LAMP	BLACK-WHITE STRIPE
15	HEADLAMP SWITCH TO HEADLAMP DIMMER SWITCH	RED-YELLOW STRIPE	81	THERMAL SW. TO BLOW MTR. CONTROL RELAY	BROWN
16	IGNITION SWITCH TO IGNITION COIL "BATT." TERMINAL	RED-GREEN STRIPE	83	HEADLAMP SW. (REAR LAMP) TO SPEEDOMETER LAMP	BLACK
17	LOW OIL PRESSURE WARNING LAMP TO LOW OIL PRESS. SNDG. UNIT	WHITE	84	WINDSHIELD WIPER/WASHER SW. TO FUSE PANEL	RED
18	AUX. CIRC. BREAKER TO GLOVE BOX LAMP	BLACK-BLUE STRIPE	87	IGNITION SW. ACCY. TERM. TO CIRC. BREAKER	GREEN-ORANGE STRIPE
19	HEADLAMP SWITCH TO INSTRUMENT PANEL LAMPS	BLUE-RED STRIPE	88	INSTR. PANEL LAMP SWITCH FEED	BLACK-WHITE STRIPE
21	BATTERY TO IGNITION SWITCH FEED	YELLOW	89	GLOW PLUG TO GLOW PLUG SWITCH	ORANGE
22	BRAKE FEED	BLUE-BLACK STRIPE	90	AIR PRESSURE GAGE TO TRANSMITTER	GREEN-WHITE STRIPE
23	CIRCUIT BREAKER TO VOLT. DIVIDER	ORANGE	92	ELECT. FUEL PUMP TO AUX. CIRC. BREAKER	BLUE
25	JUNCTION BLOCK TO HEADLAMP SWITCH	BLACK-ORANGE STRIPE	93	STARTER SWITCH TO ELECT. FUEL PUMP	BLUE-YELLOW STRIPE
26	ALTERNATOR GROUND (NEG. TERM.)	BLACK-RED STRIPE	95	WINDSHIELD WIPER CONTROL SWITCH TO GROUND	WHITE
27	WINDSHIELD WIPER CIRC. BRKR. TO W/S WIPER SWITCH	RED	96	WINDSHIELD WIPER CONTROL SW. TO W/S WIPER MOTOR GRND.	ORANGE-BLACK STRIPE
28	WINDSHIELD WIPER SW. TO WINDSHIELD WIPER MOTOR	BLACK-WHITE STRIPE	98	"A" TERM. IGN. SW. TO ALT. REG. "IGN." TERM.	BLACK
30	IGN. SW. TO CONSTANT VOLTAGE UNIT & INDICATOR LAMPS	BLACK-GREEN STRIPE	99	CONTROL SWITCH TO IGNITION SWITCH	BLACK
31	OIL PRESS. INDICATOR TO OIL PRESS. SENDING UNIT	WHITE-RED STRIPE	100	CONTROL SWITCH TO VOLTAGE REGULATOR	BLACK-RED STRIPE
32	IGNITION SWITCH TO STARTING MOTOR RELAY	RED-BLUE STRIPE	109	BATTERY TO STARTING MOTOR RELAY FEED	YELLOW
33	BATTERY TO HORN RELAY	YELLOW	110	FUEL TANK SOLENOID VALVE TO AUX. CIRC. BREAKER	BLACK-GREEN STRIPE
34	HEADLAMP DIMMER SW. TO HIGH BEAM INDICATOR LAMP	GREEN-BLACK STRIPE	113	STARTING MOTOR TO STARTING MOTOR RELAY	YELLOW-BLACK STRIPE
35	ALTERNATOR REGULATOR "F" TERM. TO ALTERNATOR	ORANGE	118	HEATER RELAY TO HEATER CIRC. BREAKER	RED
36	ALTERNATOR REGULATOR TO RECTIFIER TERM.	YELLOW-BLACK STRIPE	120	CIRCUIT BREAKER (POWER & CHARGING) TO FUSE PANEL	BLACK
37	LOAD TERM. OF AMMETER TO ALTERNATOR OUTPUT TERM.	BLACK-YELLOW STRIPE	128	STARTING MOTOR RELAY TO STARTING MOTOR	BLACK
38	LOAD THRU AMMETER TO BATTERY		129	GLOW PLUG C. B. TO GLOW PLUG SW.	GREEN
39	STARTING MOTOR RELAY BATTERY TERM. TO ALT. "A" TERM.	BLACK-RED STRIPE	130	ACCESSORY RELAY "ARM./TERM." TO ACCY. TERM. OF FUSE PANEL	YELLOW
40	TEMP. GAGE TO TEMP. SENDING UNIT	RED-WHITE STRIPE	132	MOTOR TO GROUND (2 SPEED AXLE)	GREEN
41	BATTERY TO CIGAR LIGHTER	BLUE-WHITE STRIPE	136	TWO SPEED AXLE SWITCH TO TWO SPEED ADAPTOR	BLACK
42	WARNING LAMP FEED	BLACK-YELLOW STRIPE	137	FUSE PANEL TO RADIO	YELLOW-BLACK STRIPE
43	SWITCH TO WARNING LAMP	RED-WHITE STRIPE	139	IGN. SW. "ACC." TERM. TO BATT. TERM. OF CIRCUIT BRKR.	GREEN-YELLOW STRIPE
44	IGN. TERM. OF IGN. SW. TO LOW AIR BUZZER	ORANGE-BLUE STRIPE	140	BACK UP LAMP SWITCH TO BACK UP LAMP	BLACK-RED STRIPE
45	TURN SIGNAL FLASHER TO TURN SIGNAL SWITCH	BLUE	141	TWO OR THREE SPD. AXLE SW. TO TWO OR THREE SPD. AXLE MTR.	BLACK
48	HOT WATER TEMP. RELAY TO HOT WATER TEMP. SENDING UNIT	YELLOW-RED STRIPE	142	TWO OR THREE SPEED AXLE CIRCUIT BREAKER LOAD TERM. TO TWO OR THREE SPEED AXLE TERMINAL	GREEN
49	BLIND CIRCUIT TERMINATING IN HARNESS	BLACK	143	TWO OR THREE SPD. AXLE SW. TO TWO OR THREE SPD. AXLE MTR.	RED
50	TURN SIGN. SW. TO RIGHT TURN SIG. INDICATOR LAMP	WHITE-BLUE STRIPE	144	CIRCUIT BRKR. LOAD TERM. TO NO. 142 SPLICE (2 SPEED AXLE SHIFT)	GREEN
53	TURN SIG. SW. TO LEFT TURN SIG. INDICATOR LAMP	GREEN-WHITE STRIPE	145	SPEEDO. ADAPTOR TO NO. 141, NO. 146 SPLICE (2 SPEED AXLE SHIFT)	BLACK
54	COURTESY LAMP SWITCH TO COURTESY LAMP	BLACK-BLUE STRIPE	146	SHIFT MOTOR TO NO. 141, NO. 145 SPLICE (2 SPEED AXLE SHIFT)	BLACK
55	FUSE PANEL TO COURTESY LAMP SWITCH	GREEN-YELLOW STRIPE	147	SHIFT MOTOR TO NO. 143 SPLICE (2 SPEED AXLE SHIFT)	RED
56	CARGO LAMP SW. TO CARGO LAMP	BLACK-RED STRIPE	148	HEADLAMP SW. TO AUTO. TRANS. IND. LAMP	BLACK-BLUE STRIPE
57	WINDSHIELD WIPER SW. TO WINDSHIELD WIPER MOTOR	BLUE	149	AUX. LAMP CIRCUIT BREAKER LOAD TERM. TO AUX. LAMP FEED HEADLAMP SWITCH "C" TERMINAL	YELLOW
58	GROUND CIRCUIT	BLACK	150	BATTERY FEED TO FUSE PANEL	RED
59	WINDSHIELD WIPER SW. TO WINDSHIELD WIPER MOTOR	WHITE-ORANGE STRIPE			
60	CONSTANT VOLTAGE UNIT TO GAGE	BLACK-WHITE STRIPE			
61	WINDSHIELD WIPER SW. TO WINDSHIELD WIPER MOTOR	YELLOW			
63	WINDSHIELD WIPER SW. TO WINDSHIELD WIPER MOTOR	RED			
65	WINDSHIELD WIPER SW. TO WINDSHIELD WIPER MOTOR	GREEN			
66	AIR SHIFT SWITCH TO DASH LAMP	BLUE			
67	STOP LAMP SW. TO INDICATOR LAMP	GREEN-WHITE STRIPE			
68	DEFROSTER MOTOR (FEED) TO IGN. SW. ACC. TERM.	ORANGE-BLACK STRIPE			

STANDARD WIRE COLOR CODE CHART (CONTINUED)

CIRCUIT	DESCRIPTION	COLOR	CIRCUIT	DESCRIPTION	COLOR
151	SPEED CONTROL ON-OFF SWITCH TO AMPLIFIER	BLUE-BLACK STRIPE	260	BLOWER MOTOR TO SWITCH – LO	RED-BLACK STRIPE
152	ALT. OUTPUT "A" TERM. TO VOLTAGE REG. "A" TERM.	YELLOW	261	BLOWER MOTOR TO SWITCH – HI	ORANGE-BLACK STRIPE
153	STARTING MOTOR RELAY TO FLASHER	RED-WHITE STRIPE	262	STARTING MOTOR RELAY TO IGN. COIL "I" TERM.	BROWN
154	AIR TANK VALVE	RED	263	CLICKER RELAY TERM. NO. 4 TO AIR VALVE ASSY.	RED
156	AIR TANK VALVE FEED	BLUE	264	CLICKER RELAY TERM. NO. 3 TO AIR VALVE ASSY.	BLUE
158	KEY WARNING SWITCH TO BUZZER	BLACK-WHITE STRIPE	265	CLICKER RELAY TERM. NO. 1 TO SPEED CONTROL BRAIN	WHITE
159	DOOR JAMB SWITCH TO BUZZER	RED	266	BRAKE SW. TO CLICKER RELAY TERM. NO. 4	YELLOW
160	BUZZER TO WARNING INDICATOR RELAY	WHITE	267	CONTROL HEAD MAKE READY SW. TO BRAKE SW.	BLACK-YELLOW STRIPE
161	IGN. SW. (ACC. TERM.) TO EMERG. BRAKE WARNING LAMP	GREEN	268	HEATER SW. TO HEATER BLOWER MOTOR (LOW)	RED-BLACK STRIPE
162	EMERG. BRAKE WARNING LAMP TO EMERG. BRAKE SWITCH	GREEN-RED STRIPE	269	HEATER SW. TO HEATER BLOWER MOTOR (MEDIUM)	BLUE-RED STRIPE
181	FUSE PANEL TO HEATER BLOWER MOTOR	ORANGE	270	HEATER SW. TO HEATER BLOWER MOTOR (HIGH)	BLACK-YELLOW STRIPE
182	AIR COND. CIRC. BRKR. (LOAD TERM) TO THERMOSTAT SW.	BROWN-WHITE STRIPE	271	AIR COND. MASTER SW. TO "F" TERM. OF FAST IDLE RELAY	BLUE
183	AIR COND. CIRC. BRKR. (LOAD TERM) TO A/C BLOWER SW. FEED	BROWN	272	NEUTRAL SWITCH TO "B" TERM. OF FAST IDLE RELAY	GREEN
184	AIR COND. SW. (LOW) TO AIR COND. BLOWER MOTOR	RED	273	IGN. SWITCH TO FAST IDLE RELAY	YELLOW
185	AIR COND. SW. (HIGH) TO AIR COND. BLOWER MOTOR	BLACK	274	FAST IDLE RELAY TO STARTING MOTOR RELAY	RED
188	CIRCUIT BRKR. TO HEADLAMP SW. "BATT." TERM.	BLACK	275	FAST IDLE RELAY "A" TERM. TO FAST IDLE SOLENOID	BLACK
189	TERM. BLOCK TO CIRCUIT BREAKER	GREEN-YELLOW STRIPE	276	STARTING MOTOR RELAY TO NEUTRAL SWITCH	YELLOW
190	IGNITION SW. ACCY. TERM. TO AIR COND. CIRCUIT BREAKER	YELLOW	277	BLOWER MOTOR TO SWITCH	GREEN
195	EMERG. BRAKE SW. TO SIGNAL LAMP & RESISTOR GND.	RED	280	COORDINATOR SW. TO WINDSHIELD WIPER MOTOR	WHITE-GREEN STRIPE
196	ACCY. FEED FROM FUSE PANEL TO RELAY	RED	281	COORDINATOR SW. TO WINDSHIELD WIPER MOTOR	BLUE-BLACK STRIPE
197	AUX. ACCY. FEED FROM RELAY	RED-BLUE STRIPE	282	TURN SIGNAL SW. TO RH REAR TURN SIGNAL LAMP	GREEN
198	BATT. TERM. OF STARTER SOLENOID TO RELAY	BLACK	283	TURN SIGNAL SW. TO LH REAR TURN SIGNAL LAMP	YELLOW-BLACK STRIPE
199	CIRCUIT BREAKER FEED	BLACK-ORANGE STRIPE	284	BATTERY FEED TO STOPLAMP SWITCH	RED
200	CIRCUIT BREAKER TO SPLICE	BLUE	285	"R" TERMINAL HEADLAMP SWITCH TO REAR LAMPS	BROWN
201	SPLICE TO HEADLAMP SWITCH	BLUE-YELLOW STRIPE	286	FUEL GAGE INDICATOR TO TANK SENDING UNIT	ORANGE
203	INTERIOR LAMP PICKUP BOX COVER	WHITE-YELLOW STRIPE	288	"R" TERM. OF ALT. REG. TO ALT. "R" TERM.	WHITE-BLACK STRIPE
205	CIRC. BRKR. LOAD TERM. TO STOPLAMP WRNG. RELAY ARM. TERM.	GREEN	289	FAST IDLE RELAY "A" TERM. TO COMPRESSOR CLUTCH	BLACK
206	GROUND RETURN TO TOWING VEHICLE	WHITE	292	REAR TERM. OF HEADLAMP SW. TO STORAGE COMPT. LAMP	WHITE
207	MARKER LAMP SWITCH TO MARKER LAMPS	BLACK	296	FUSE PANEL ACCY. FEED TO SPLICE	RED
208	WATER TEMP. SW. (HOT) TO DELAY & CONTROL RELAY	RED-WHITE STRIPE	297	IGN. SW. (ACCY. TERM) TO FUSE PANEL ACCY. FEED	BLACK-GREEN STRIPE
209	STOPLAMP SW. TO RELAY	YELLOW	331	WINDSHIELD WASHER SW. (FLOOR) TO W/SHIELD WIPER SW.	RED
210	INDICATOR LAMP TO SWITCH	BLUE	332	WINDSHIELD WASHER SW. FEED (FLR.) TO IGN. SW. ACCY. TERM	YELLOW
212	AUX. CIRC. FEED TO TRACTOR TRAILER PLUG	BLUE	345	RELAY NO. 1 TERM. TO POST. TERM. VOLT. REG.	GREEN-WHITE STRIPE
213	OIL LEVEL SENDER TO SIGNAL UNIT (LAMP)	RED	346	RELAY NO. 2 TERM. TO BATT. TERM. START RELAY	WHITE-GREEN STRIPE
214	SIGNAL UNIT (LAMP) TO TEMP. SIGNAL LAMP	RED-BLACK STRIPE	347	THERMOSTATIC SW. TO CLUTCH	BLACK
215	SIGNAL UNIT (LAMP) TO FUEL SIGNAL RELAY	YELLOW-BLACK STRIPE	348	THERMOSTATIC SW. TO AIR COND. SW. SELECTOR TERM.	GREEN-WHITE STRIPE
221	IGNITION SW. "ACCY. TERM" TO HEATER TEMPERATURE SW. FD.	BLUE	349	THERMOSTATIC SW. TO AIR COND. SW.	BROWN
222	TEMPERATURE CONTROL SW. TO HEATER MOTOR BLOWER SW.	RED	350	AIR COND. SW. "HI" TERM. TO CLUTCH RELAY "BATT." TERM.	YELLOW
230	EMISSION CONTROL VALVE TO SWITCH	BROWN-YELLOW STRIPE	351	CLUTCH RELAY TO CLUTCH	RED
231	"L" TERM. VOLTAGE REG. TO ACCESSORY TERM. IGN. SW.	YELLOW-BLACK STRIPE	358	IGN. SW. (ACCY. TERM) TO AIR COND. EVAPORATOR MOTOR SW.	YELLOW
232	ELECTRONIC SW. TO IGN. COIL NEG. TERM.	GREEN-YELLOW STRIPE	359	EVAPORATOR THERMOSTAT TO COMPRESSOR CLUTCH	BLACK-WHITE STRIPE
233	WINDSHIELD WASHER MOTOR TO IGN. SW.	GREEN	360	SPEED CONTROL BRAKE SW. TO SPEED CONTROL IND. LAMP	YELLOW-BLUE STRIPE
234	WINDSHIELD WASHER MOTOR TO IGN. SW.	BLACK	364	ACCY. TERM. IGN. SW. (FUSE PANEL) TO BLWR. (COIL TERM) MTR. RELAY	BLACK-GREEN STRIPE
235	ALTERNATOR RELAY TO ALTERNATOR REGULATOR	YELLOW-BLACK STRIPE	369	VACUUM SOLENOID TO TEMP. SW.	BROWN
252	CIRCUIT BREAKER (LOAD) TO 3 SPEED AXLE SWITCH	GREEN	370	AIRSHIFT SW. TO BATT. TERM. OF IGN. SW.	YELLOW
253	INTERMEDIATE TERMINAL 3 SPEED AXLE SWITCH TO SOLENOID VALVE FORWARD TANDEM	RED	371	BLOWER MOTOR RELAY (LOAD TERM) TO BLOWER MOTOR	RED
254	HIGH TERM. 3 SPEED AXLE SW. TO SOLE. VALVE RR. TANDEM	BLACK	373	BATTERY FEED TO CIRCUIT BREAKER (BATT. TERM)	YELLOW
255	CIRCUIT BREAKER (LOAD) TO AXLE LOCKOUT DIFFERENTIAL	BLUE	374	STARTING MOTOR RELAY TO ENGINE USAGE INDICATOR	RED
256	ACCESSORY TERM IGN. SW. TO 3 SPEED AXLE SWITCH	GREEN	376	HORN BUTTON TO HORN	BLUE-YELLOW STRIPE
257	IGN. SW. "ACCY. TERM." TO BLOWER MOTOR	YELLOW	377	AUX. CIRCUIT BRKR. TO HORN BUTTON	YELLOW-BLUE STRIPE
258	EMERG. BRAKE WARNING LAMP TO EMERG. BRAKE SWITCH	BLACK	383	EMERGENCY WARNING FLASHER FEED	RED-WHITE STRIPE
259	IGN. SW. TO EMERG. BRAKE WARNING LAMP	BLACK-RED STRIPE			

STANDARD WIRE COLOR CODE CHART (CONTINUED)

CIRCUIT	DESCRIPTION	COLOR	CIRCUIT	DESCRIPTION	COLOR
384	FLASHER TO EMERGENCY WARNING LAMP	WHITE-BLUE STRIPE	579	RELAY TO JUNCTION BLOCK	BLACK-ORANGE STRIPE
385	FLASHER TO EMERGENCY WARNING SWITCH	WHITE-RED STRIPE	580	FUSE PANEL TO ANTI-SKID	BLUE
386	FLASHER TO EMERGENCY WARNING INDICATOR	YELLOW	581	FAILURE MODULE TO RELAY	GREEN-WHITE STRIPE
388	AUX. CIRCUIT BREAKER FEED	YELLOW-RED STRIPE	583	INTERMITTENT GOV. TO INTERMITTENT GOV. FEED	BLACK
399	FUSE PANEL TO HEATER BLOWER SWITCH	BROWN	584	IGN. SW. TO SEAT BELT WARNING IND.	GREEN-BLUE STRIPE
450	IGN. SW. TO SEAT BELT WARNING INDICATOR LAMP FEED	GREEN	587	W/SHLD. WIPER SW. TO INTERMITTENT GOVERNOR FEED	BLACK-WHITE STRIPE
451	SEAT BELT WARNING LAMP TO SEAT BELT WARNING IND. RELAY TERM. NO. 1	BLACK-RED STRIPE	588	W/SHLD. WIPER MOTOR DYN. BRAKE TO W/S WIPER SW. GRND.	WHITE-BLACK STRIPE
452	IGN. SW. TO SEAT BELT WARNING IND. RELAY TERM NO. 4	GREEN-WHITE STRIPE	589	W/SHLD. WIPER SW. TO INTERMITTENT GOV. GRND. DYN. BRKG.	ORANGE
453	SEAT BELT WARNING IND. GRD. SW. TO S/B WRNG. IND. RELAY TERM. NO. 2	BLACK-YELLOW STRIPE	590	INTERMITTENT GOVERNOR TO W/S WIPER SWITCH	BLUE-WHITE STRIPE
454	IGN. SW. COIL TERM. TO CIRCUIT BREAKER	RED-GREEN STRIPE	591	SPEED CONTROL RELAY TO SPEED REGULATOR	BLACK-ORANGE STRIPE
455	CIRCUIT BREAKER TO FUEL VALVE	GREEN-RED STRIPE	592	STOPLAMP SW. TO SPEED CONTROL RELAY	BLUE-WHITE STRIPE
460	BATTERY TO HORN SWITCH	YELLOW	593	SPEED CONTROL ACTUATOR TO CUTOFF RELAY	YELLOW
469	IGN. SW. ACCY. TERM. TO SEAT BELT WARNING SWITCH	GREEN	594	TEMP. TRANSMITTER TO IND. LAMP (ENGINE COLD)	GREEN
474	IGNITION SW. (ACCY.) TO STOPLAMP RELAY (BATT. TERM.)	RED	596	PRIMER SW. TO OIL PRESSURE SAFETY SWITCH	BLACK
475	STOPLAMP SW. TO STOPLAMP RELAY (COIL TERM.)	GREEN-WHITE STRIPE	597	COIL TERM. OF IGN. SW. TO OIL PRESSURE SAFETY SW.	RED
477	CIRCUIT BREAKER TO FOG LAMP SWITCH	BLUE-BLACK STRIPE	598	COIL TERM. OF IGN. SW. TO FUEL PUMP PRIMER SWITCH	RED-BROWN STRIPE
478	FOG LAMP SWITCH TO FOG LAMP	GRAY	599	START TERM. OF IGN. SW. TO FUEL PUMP PRIMER SWITCH	RED-BLUE STRIPE
480	HI LAMP FEED FROM HEADLAMP SWITCH TO FUSE PANEL	YELLOW-ORANGE STRIPE	600	FAILURE MODULE TO TANDEM RR. AXLE CONTROLLER	BLUE-BLACK STRIPE
483	INHIBITOR SWITCH TO MAKE READY SWITCH	YELLOW-BLUE STRIPE	601	BRAKE SKID CONTROL MODULE FEED	BLUE
484	CLICKER RELAY TERM. NO. 1 TO RESUME SPEED SWITCH	BLACK	602	COIL TERM. OF IGN. SW. TO BRAKE SKID CONTROL MODULE	RED-PURPLE STRIPE
489	EMERGENCY FLASHER SWITCH TO STOPLAMP RELAY	ORANGE	603	DUAL BRAKE WARNING LIGHT TO BRAKE SKID CONTROL MODULE	GREEN
490	IGNITION SWITCH TO TRANSMISSION INDICATOR LAMP	BLUE-RED STRIPE	604	SKID CONTROL MODULE TO R. H. WHEEL SENSOR (HIGH)	YELLOW
491	CIRC. BREAKER (BATT. TERM) TO STOPLAMP RELAY (BATT. TERM)	RED-WHITE STRIPE	605	SKID CONTROL MODULE TO R. H. WHEEL SENSOR (LOW)	BROWN
492	STOPLAMP RELAY (ARM TERM.) TO TURN SIGNAL SWITCH	GREEN	606	SKID CONTROL MODULE TO L. H. WHEEL SENSOR (HIGH)	YELLOW
509	AIR COND. CONDENSOR THERMAL SWITCH FEED	YELLOW	607	SKID CONTROL MODULE TO L. H. WHEEL SENSOR (LOW)	BROWN
510	AIR COND. CONDENSOR THERMAL SW. TO BLOWER MOTOR	ORANGE	608	FAILURE MOD. TO FRONT AXLE CONTROL	BLUE-WHITE STRIPE
511	STOPLAMP SW. TO TURN SIGNAL SW.	GREEN	609	ESOTP MODULE TO THERMOCOUPLE (NEG.)	RED
512	SWITCH TO TRAILER AUX. LAMPS	BLACK	610	THERMOCOUPLE (-) MODULE TO SENSOR	RED-YELLOW STRIPE
513	CIRCUIT BREAKER TO STOPLAMP RELAY FEED	BROWN	611	THERMOCOUPLE (+) MODULE TO SENSOR	YELLOW
514	EMERGENCY WRNG. SW. TO EMERG. WRNG. RELAY COIL TERM.	BLUE	612	AIR DUMP VALVE (-) TO MODULE	BLUE
515	HEATER RESISTOR TO BLOWER MOTOR (HI)	ORANGE	613	EGR VALVE (-)	BROWN
519	GLOW PLUG SW. TO LAMP (FEED)	WHITE	614	SPEED SENSOR	GREEN
520	SEAT BELT WARNING LAMP TO WARNING LAMP SWITCH	VIOLET-WHITE STRIPE	615	FEED TO FAILURE SWITCH	BLACK-YELLOW STRIPE
526	CIRCUIT BREAKER TO MARKER LAMP SW. FEED	BLACK-WHITE STRIPE	617	FUSE PANEL TO SKID CONTROL MODULE	BLACK-GREEN STRIPE
532	IGNITION SWITCH TO VACUUM SWITCH	ORANGE	618	FAILURE MOD. TO RR. AXLE CONTROL	RED
533	VACUUM SWITCH TO INDICATOR LAMP	BLACK	619	FAILURE MOD. TO RR. AXLE CONTROL	GREEN-YELLOW STRIPE
536	BLOWER MOTOR RELAY (LOAD TERM) TO BLOWER MOTOR	BLACK	620	FAILURE MOD. TO RR. AXLE CONTROL	BLUE
537	COMPRESSOR TO CLUTCH	YELLOW	621	FAILURE MOD. TO FRONT AXLE CONTROL	GREEN
546	STARTER CONTROL TO INTERLOCK MODULE	WHITE-PINK STRIPE	622	FAILURE MOD. TO FRONT AXLE CONTROL	RED-WHITE STRIPE
560	SEAT BELT WRNG. TIMER TO L.F. RETRACTOR SWITCH	BROWN-BLUE STRIPE	625	IGNITION SW. COIL TERM. TO PRIMER SWITCH	BLUE
561	SEAT BELT WRNG. TIMER TO R.F. SEAT SENSOR	BLUE-WHITE STRIPE	629	FAILURE MOD. TO RR. AXLE CONTROL	RED-BLACK STRIPE
562	SENSOR SIGNAL TO AMPLIFIER	GREEN-WHITE STRIPE	630	FUSE PANEL TO FAILURE INDICATOR RELAY	WHITE
563	AUX. HEADLAMP SW. TO AUX. HD. LAMP RELAY	BROWN	631	FAILURE MOD. TO TAN. RR. AXLE CONTROL	GREEN-BLACK STRIPE
564	HEADLAMP SW. TO AUX. HEADLAMP RELAY	ORANGE	632	IGN. SW. COIL TERM. TO OIL TEMP. WARNING LAMP	BLACK
565	AUX. HEADLAMPS TO AUX. HD. LP. RELAY	BLUE	633	IGN. SW. TO OIL TEMP. WARNING RELAY	RED
568	ALTERNATOR RELAY TO ALTERNATOR REGULATOR	GREEN	634	OIL TEMP. WARNING RELAY TO OIL TEMP. WARNING LAMP	BLUE
569	INTERLOCK MODULE TO CENTER BUCKLE SWITCH	ORANGE-WHITE STRIPE	635	OIL TEMP. WARNING LAMP TO OIL TEMP. WARNING SWITCH	GREEN
570	INTERLOCK MODULE TO CENTER SEAT SENSOR	YELLOW-GREEN STRIPE	636	OIL TEMP. WARNING RELAY TO OIL TEMP. SW.	GREEN
572	ENGINE WARNING SYSTEM	RED-WHITE STRIPE	637	OIL TEMP. WARNING RELAY TO FLASHER	BLACK
575	LIGHT SWITCH FEED	RED-BLACK STRIPE	638	FLASHER TO OIL PRESS. SWITCH	YELLOW
576	LIGHT SWITCH TO RELAY	BLUE	639	FLASHER TO OIL TEMP. WARNING LAMP	YELLOW-RED STRIPE
577	FUSE PANEL TO CIRCUIT BREAKER	GREEN	640	IGN. SWITCH COIL TERM. TO WARNING LAMPS	RED-YELLOW STRIPE
578	CIRCUIT BREAKER TO RELAY FEED	YELLOW	641	IGN. SWITCH GROUND TERM. TO WARNING LAMP	BLACK-RED STRIPE
			642	WATER TEMP. WARNING LAMP TO WATER TEMP. SW. (COLD)	WHITE-GREEN STRIPE
			643	CHARGE INDICATOR LAMP TO SPLICE	YELLOW-BLACK STRIPE

STANDARD WIRE COLOR CODE CHART (CONTINUED)

CIRCUIT	DESCRIPTION	COLOR	CIRCUIT	DESCRIPTION	COLOR
644	OIL TEMP. WARNING LAMP TO IGN. SWITCH (ACCY. TERM.)	RED-GREEN STRIPE	780	ENGINE ALARM RELAY (OIL PRESS.) "F" TERM. TO "A" TERM. IGNITION SWITCH	RED
645	IGNITION SWITCH COIL TERMINAL TO TACHOMETER	BLACK	781	BRAKE PAD SWITCH TO HOLDING RELAY	BROWN
646	TACH. THRU IGN. RESISTOR TO BATTERY TERM. OF IGN. COIL	RED	784	STEREO SPEAKER VOICE COIL RETURN	VIOLET
647	WATER TEMP. WARNING LAMP TO WATER TEMP. SWITCH (HOT)	RED	786	FUEL PUMP PRIMER SW. TO FUEL PUMP RELAY	RED
648	IGNITION SW. COIL TERMINAL TO TACHOMETER	RED	787	FUEL PUMP SAFETY SWITCH TO FUEL PUMP MOTOR	RED-BROWN STRIPE
649	TACHOMETER TO IGNITION COIL "B" TERM.	RED-GREEN STRIPE	789	VACUUM SWITCH TO HOLDING RELAY	BROWN-WHITE STRIPE
654	ALT. SHUNT "A" TERM. TO AMMETER	YELLOW-BLACK STRIPE	795	NEUTRAL SAFETY RELAY TO NEUTRAL SWITCH	RED-BLACK STRIPE
655	STARTING MOTOR RELAY SHUNT TO AMMETER	RED-ORANGE STRIPE	796	ACCESS. FEED TO NEUTRAL SAFETY RELAY	BLACK
666	DOME LAMP FEED	RED	797	BATTERY FEED TO STEREO	GREEN
668	IGN. RELAY TO STARTING MOTOR RELAY	BLACK	804	FADER CONTROL TO FADER ARM (LEFT CHANNEL)	RED
669	IGN. RELAY TO STARTING MOTOR RELAY START TERM.	RED-BLUE STRIPE	805	FADER CONTROL TO FADER ARM (RIGHT CHANNEL)	BLUE
670	FAILURE INDICATOR TO MODULE	PINK	806	SPEAKER VOICE COIL FEED (RIGHT CHANNEL)	WHITE
671	SPEED REG. SW. "ON" POSITION TO ON & OFF RELAY	WHITE	807	SPEAKER VOICE COIL FEED (LEFT CHANNEL)	ORANGE
672	SELECTOR SW. TO LEFT HAND PUMP MOTOR	BROWN	808	SELECTOR SWITCH TO FUEL TANK SOLENOID VALVE	BROWN-ORANGE STRIPE
673	SELECTOR SW. TO LEFT FUEL GAGE	GREEN	809	STOPLAMP SWITCH TO STOPLAMP	RED-BLACK STRIPE
674	SELECTOR SW. TO RIGHT HAND PUMP MOTOR	BROWN-WHITE STRIPE	810	STOPLAMP SWITCH TO STOPLAMP	RED-BLACK STRIPE
675	SELECTOR SW. TO RIGHT FUEL GAGE	GREEN-RED STRIPE	811	RELAY "A" TERM. TO TRAILER TAIL LAMPS	BROWN
676	L. H. SENSOR FEED JUNCTION BLOCK TO CONTROLLER	ORANGE	812	MARKER LAMP SWITCH TO MIRROR LAMP	BLUE
677	L. H. SENSOR COMMON JUNCTION BLOCK TO CONTROLLER	GREEN	813	BRAKE SWITCH TO TRAILER RELAY "B" TERM.	YELLOW-BLACK STRIPE
678	R. H. SENSOR COMMON JUNCTION BLOCK TO CONTROLLER	GREEN-WHITE STRIPE	814	IGN. SWITCH COIL TERM. TO VOLTAGE RELAY	WHITE
679	R. H. SENSOR FEED JUNCTION BLOCK TO CONTROLLER	ORANGE-WHITE STRIPE	816	CIRCUIT BREAKER TO REVERSE RELAY FEED	YELLOW-BLUE STRIPE
682	H/L SW. BATT. TERM. TO TRACTOR-TRAILER RELAY "B" TERM.	YELLOW	822	FRONT SPEAKER TO FADER CONTROL SWITCH	BROWN
683	H/L SW. "R" TERM. TO TRACTOR-TRAILER RELAY "F" TERM.	BROWN	823	FADER CONTROL SWITCH TO RADIO	GREEN
684	TRACTOR-TRAILER RELAY "A" TERM. TO MARKER LAMP SW.	BLACK-WHITE STRIPE	824	FRONT SPEAKER TO RADIO	BLUE
685	TRACTOR-TRAILER RELAY CIRC. BRKR. TO AUX. MARKER LAMP SW.	BLACK-RED STRIPE	825	SERVO SOURCE VACUUM SOLE. TO CONTROL TRANSISTOR	GRAY-BLACK STRIPE
689	ENG. SPEED SENSOR UNIT TO MANIFOLD VACUUM SENSING SW.	PURPLE	826	SERVO VENT VACUUM SOLE. TO CONTROL TRANSISTOR	WHITE-PINK STRIPE
690	HYDRO-BOOST SW. TO WARNING LAMP	GREEN-WHITE STRIPE	827	SERVO FEEDBACK POTENTIOMETER SIGNAL TO AMPLIFIER	YELLOW-RED STRIPE
691	SKID CONTROL MODULE TO AXLE SENSOR	YELLOW	828	SERVO FEEDBACK POTENTIOMETER BASE TO AMPLIFIER	BROWN-GREEN STRIPE
692	SKID CONTROL WARNING RELAY TO SKID CONT. MODULE	BROWN	829	IGN. SW. (ACCY. TERM.) TO VACUUM SOLENOID	RED
693	BRAKE SYSTEM WARNING RELAY TO SW.	BROWN	830	SENSOR SIGNAL TO AMPLIFIER	GREEN-WHITE STRIPE
694	TURN SIG. FLASHER "P" TERM. TO TURN SIGNAL IND. LAMPS	BROWN	832	CONTROL RELAY TO HOLDING RELAY	YELLOW-BLACK STRIPE
697	SPEED REG. SW. "OFF" POSITION TO ON & OFF RELAY	ORANGE-BLACK STRIPE	833	IGN. SW. ACCY. TERM. TO EMERGENCY STOP LAMP SW.	GREEN
704	FRONT RADIO SPEAKER VOICE COIL GROUND	BLACK-RED STRIPE	836	INDICATOR LAMP TO FLASHER	RED
705	CIRCUIT BREAKER TO HEATER BLOWER SWITCH	BROWN	837	FLASHER TO EMERGENCY BRAKE SWITCH	BLACK
708	RADIO SPEAKER VOICE COIL FEED	BLACK-ORANGE STRIPE	838	THERMAL RELAY TO LOCK IN VALVE	ORANGE-BLACK STRIPE
730	BATTERY TO VOLT METER	RED	839	BATTERY TO STOP LAMP CIRCUIT BREAKER	WHITE
733	AMPLIFIER GROUND BREAKER LESS MODULE TO DISTRIBUTOR	BLACK-GREEN STRIPE	847	STARTER RELAY SOLENOID "SM" TERM. TO C. S. RELAY COIL	WHITE
734	AMPLIFIER TO SERVO TRANSDUCER FEED	ORANGE-YELLOW STRIPE	848	BALLAST RESISTOR "E" TERM. TO TRANSISTOR UNIT "E" TERM.	RED-WHITE STRIPE
735	AMPLIFIER FEEDBACK POTENTIOMETER FEED	PURPLE-BLUE STRIPE	849	STARTING MOTOR RELAY TO TACH BLOCK	BROWN
737	AIR CONDITIONER MOTOR TO GROUND	GREEN	850	BALLAST RESISTOR COIL TERM. TO IGN. COIL BATT. TERM.	BLUE-WHITE STRIPE
738	FUEL PUMP RELAY "H" TERMINAL TO OIL PRESSURE SWITCH	GREEN-ORANGE STRIPE	851	TRANSISTOR UNIT "B" TERM. TO DISTRIBUTOR	GREEN
739	FUEL PUMP RELAY TO SELECT SWITCH "B" TERMINAL	RED-YELLOW STRIPE	852	TRANSISTOR UNIT "C" TERM. TO BALLAST RESISTOR "C" TERM.	BLUE
740	IGNITION SWITCH (COIL TERM.) TO FUEL PUMP RELAY	GREEN	853	COIL TERM. IGN. SW. TO BALLAST RESISTOR "E" TERM.	RED-GREEN STRIPE
741	IGNITION SWITCH (ACCY. TERM.) TO FUEL PUMP RELAY	RED	854	C. S. RELAY TO STARTER SOLENOID "I" TERM.	BROWN
742	FUEL PUMP RELAY TO FUEL PUMP	BLUE	855	TRANSISTOR UNIT TO PICK-UP COIL	VIOLET
743	FUEL PUMP RELAY TO OIL PRESSURE SW.	YELLOW	856	PICK-UP COIL TO TRANSISTOR UNIT	ORANGE
747	FUSE PANEL TO RADIO RECEIVER	BLACK	857	TRANSISTOR UNIT TO START TERM. TO STARTER RELAY	WHITE
748	A/C MODE SHIFT TO HEATER CONTROL SWITCH	BLUE	858	MAKE READY SWITCH TO BRAKE PEDAL PAD SWITCH	RED
749	RADIO RECEIVER TO F. M. TUNER FEED	BLACK	859	BRAKE PEDAL PAD SWITCH TO CONTROL RELAY TERM. NO. 4	YELLOW
763	ACC. TERM. OF IGN. SW. TO W/S WIPER CIRCUIT BREAKER	ORANGE-WHITE STRIPE	860	MAKE READY SWITCH TO SET SPEED SWITCH	VIOLET-WHITE STRIPE
764	W/S WIPER CIRCUIT BREAKER TO W/S WIPER MOTOR	BLACK-ORANGE STRIPE	861	RETARD SWITCH TO CONTROL RELAY TERM. NO. 7	BLUE-WHITE STRIPE
778	SEAT BELT SW. FEED "P" TERM.	YELLOW			
779	MARKER LAMP SWITCH TO BLINK SWITCH	WHITE-BLACK STRIPE			

STANDARD WIRE COLOR CODE CHART (CONTINUED)

CIRCUIT	DESCRIPTION	COLOR	CIRCUIT	DESCRIPTION	COLOR
862	RESUME SWITCH TO CONTROL RELAY TERM. NO. 8	WHITE-BLUE STRIPE	919	TRANS. NEUTRAL SW. TO INDICATOR LAMP	BLUE
863	BRAKE SWITCH TO HOLDING RELAY	BLACK-YELLOW STRIPE	920	BRAKE SW. TO SPEED CONTROL REG.	YELLOW
864	BRAKE SWITCH TO 20 M.P.H. SWITCH	ORANGE	921	SPEED CONTROL "OFF POSITION" TO SPEED REGULATOR	GREEN-VIOLET STRIPE
865	SELECTOR SWITCH TO WARNING LAMP (LOW OIL PRESSURE)	BLACK	922	SPEED CONTROL "ON POSITION" TO SPEED REGULATOR	WHITE
866	CONTROL SWITCH TO OIL PRESSURE PUMP	BLACK	923	SPEED CONTROL SW. TO SPEED REG. SOLENOID	VIOLET
867	IGNITION SWITCH TO OIL PRESSURE SWITCH	RED	924	HOLDING RELAY TO SPEED CONTROL SW. FEED	RED
868	OIL PRESSURE SWITCH TO CONTROL SWITCH	RED-BROWN STRIPE	925	SPEED CONTROL SW. TO SPEED REG. COUPLING COIL	WHITE-ORANGE STRIPE
869	RETARD VALVE TO CONTROL RELAY TERM. NO. 1	GREEN-YELLOW STRIPE	926	HEATER BLOWER MOTOR SW. TO BLOWER MOTOR MED.	RED-BLUE STRIPE
870	EMERGENCY STOP LAMP SWITCH TO TRACTOR-TRAILER PLUG	BLACK-WHITE STRIPE	931	SPEED CONTROL SWITCH TO SPEED REG.	BLACK
871	LOCK-IN VALVE TO CONTROL RELAY TERM. NO. 2	RED-WHITE STRIPE	932	IGN. SWITCH TO THROTTLE SOLENOID	BLUE
872	STARTER MOTOR RELAY TO CONTROL RELAY TERM. NO. 11	RED-BLUE STRIPE	933	EMISSION MODULATOR CONTROL FEED	RED
873	HEADLAMP SWITCH "R" TERM. TO ASH RECPT. LAMP FEED	WHITE-BLACK STRIPE	934	EMISSION SPEED SENSOR TO MODULATOR CONTROL	BLUE
876	HEADLAMP SW. BATT. TERM. TO ALT. "A" TERM.	YELLOW	935	TRANSISTOR BASE TERM. TO DIST. TERM. OF IGN. COIL	BLUE
877	ALT. "F" TERM. TO REG. "F" TERM.	WHITE	936	TRANSISTOR EMITTER TERM. TO TRANSISTOR TERM. OF IGN. COIL	BLACK
878	REG. "A" TERM. TO IGN. SW. COIL TERM.	GREEN	937	EMISSION SPEED SENSOR GROUND	BLACK
879	BLOWER SW. MED. NO. 1 THRU RESISTOR TO HI BLOWER MOTOR FIELD	BLACK-ORANGE STRIPE	939	MODULATOR TO THERMO SWITCH	GRAY
880	BLOWER SW. MED. NO. 2 TO LOW BLOWER MOTOR FIELD	BLACK-RED STRIPE	941	WASHER CONTROL SW. TO WASHER PUMP MOTOR FEED	BLACK-WHITE STRIPE
881	20 MPH SWITCH TO CONTROL RELAY TERMINAL NO. 16	GRAY	943	TRACTOR TRAILER RELAY "B" TERM. TO TRACTOR TRAILER CIRC. BRKER. LOAD TERM.	GREEN
882	A/C BLOWER SW. TO A/C REFRIGERANT SOL. FEED	WHITE	948	FLASHER TO R. H. LAMP	ORANGE
883	CIRCUIT BREAKER TO A/C CONTROL RELAY	ORANGE	949	FLASHER TO L. H. LAMP	BLUE
884	A/C CONTROL RELAY TO A/C SW. (FEED)	YELLOW	950	FUSE PANEL TO WASHER CONTROL SWITCH	WHITE-BLACK STRIPE
885	ACCY. TERM. IGN. SW. TO A/C CONTROL RELAY	WHITE	951	WASHER CONTROL SW. TO WASHER PUMP MOTOR FEED	GREEN-BLACK STRIPE
886	LAMP TO SENDING UNIT	BLUE	952	BATTERY TO TRACTOR TRAILER CIRC. BREAKER BATT. TERM.	YELLOW-BLUE STRIPE
887	SPLICE TO OIL TEMP. ENG.	RED	953	COORDINATOR SW. TO W/SHIELD WIPER MOTOR	WHITE-ORANGE STRIPE
888	W/SHIELD WIPER SWITCH TO RELAY	RED	954	W/SHIELD WIPER SW. TO COORDINATOR SW. FEED	BLACK-WHITE STRIPE
889	W/SHIELD WIPER SWITCH TO RELAY	GREEN	955	W/SHIELD WIPER MOTOR ARM RH TO W/S WIPER SWITCH	RED-ORANGE STRIPE
890	W/SHIELD WIPER SW. TO RELAY	YELLOW	956	W/SHIELD WIPER SW. TO W/SHIELD WIPER MOTOR FIELD RH	GREEN-ORANGE STRIPE
891	W/SHIELD WIPER MOTOR TO RELAY	YELLOW-BLACK STRIPE	957	W/SHIELD WIPER SWITCH FEED TO IGN. SWITCH	YELLOW
892	W/SHIELD WIPER SW. TO RELAY	BLUE	958	ACCY. TERMINAL IGN. SW. TO WASHER CONTROL SW.	WHITE
893	W/SHIELD WIPER MOTOR TO RELAY	BLUE-ORANGE STRIPE	960	AUX. HEATER FEED TO SWITCH	RED
895	IGN. SW. TO W/SHIELD WIPER MOTOR CIRCUIT BREAKER	RED	961	GLOW PLUG SW. TO GLOW PLUG WARNING LAMP	BLACK-WHITE STRIPE
896	IGN. SW. COIL TERM. TO IND. LAMPS, OIL PRESS. & WATER TEMP.	BLACK	962	DIFF. TEMP. SW. TO FRONT DIFFERENTIAL	RED
897	CONTROL RELAY TO THERMAL RELAY	RED	963	DIFF. TEMP. TO REAR DIFFERENTIAL	GREEN
898	BRAKE SWITCH TO VACUUM SWITCH	GREEN	964	ALT. TO REG. FIELD CONTROL	BLUE
899	ALTERNATOR NEU.-TERM. TO ALT. REG. (NEU.-TERM.)	RED	965	RELAY (BATT. TERM.) TO BATT. CUT-OFF SWITCH	BLACK
900	ALTERNATOR AUX. TERM. TO IGN. SW. ACCY. TERM.	RED-GREEN STRIPE	973	BATTERY FEED TO FUEL CONTROL VALVE	RED
901	ALTERNATOR AUX. TERM. TO CHARGE IND. LAMP	YELLOW-BLACK STRIPE	974	FUEL CONTROL SWITCH TO FUEL CONTROL VALVE	ORANGE
902	ALTERNATOR RECTIFIER (+TERM.) TO LOAD	BLACK-YELLOW STRIPE	975	TRANSMISSION TEMPERATURE LAMP INDICATOR FEED	RED-GREEN STRIPE
903	ALTERNATOR AUX. TERM. TO ALT. REG. FIELD FEED TERM.	GREEN-RED STRIPE	976	FUSE PANEL TO FUEL GAGE INDICATOR	BLACK-GREEN STRIPE
904	(COIL/ACCY.) - TERM. OF IGN. SW. TO ALT. REG. (IGN. TERM.)	GREEN-RED STRIPE	977	BRAKE WARNING SWITCH TO INDICATOR LAMP	VIOLET-WHITE STRIPE
905	AIR COND. SW. "MED." TO BLOWER MOTOR	BLUE	984	MARKER LAMP SWITCH TO MARKER LAMP	BROWN
906	IGN. SW. (ACCY. TERM.) TO CIRCUIT BREAKER	BLACK-YELLOW STRIPE	985	TURN SIGNAL RELAY TO LEFT TURN SIGNAL SWITCH	RED
907	HOLDING RELAY TO 25 MPH SW.	BLACK-ORANGE STRIPE	986	TURN SIGNAL RELAY TO RIGHT TURN SIGNAL SWITCH	BROWN
908	STARTING MOTOR RELAY TO LOCK IN COIL	YELLOW	987	TURN SIGNAL RELAY TO LEFT TURN CANCEL SWITCH	RED-BLUE STRIPE
910	BRAKE SWITCH TO AIR VALVE	BLUE-WHITE STRIPE	988	TURN SIGNAL RELAY TO RIGHT TURN CANCEL SWITCH	BROWN-BLUE STRIPE
911	FUSE PANEL (ACCY. FEED) TO SPEED REGULATOR SWITCH	ORANGE-WHITE STRIPE	990	RELAY TO INDICATOR LAMP	BLACK-YELLOW STRIPE
912	SPEED REGULATOR SWITCH TO SELECTOR SWITCH	YELLOW	993	INTERMITTENT GOVERNOR TO WINDSHIELD WIPER SWITCH	BROWN-WHITE STRIPE
913	HEATER RESISTOR TO BLOWER MOTOR (HI)	YELLOW	994	ELECTRIC COOLING P.V.S. SWITCH	YELLOW
914	FUSE PANEL TO SPEED REG. SW. FEED	GREEN	995	HEADLAMP SWITCH TO LO-BEAM OF HEADLAMP	RED-BLACK STRIPE
915	SPEED REG. BRAKE SW. TO SPEED REG. COIL	BLACK-ORANGE STRIPE	996	HEADLAMP SWITCH TO WORKLAMP	YELLOW-BLACK STRIPE
916	SPEED REG. COIL TO AUTOMATIC CONTROL	RED	997	IMPLEMENT LAMP SW. TO IMPLEMENT LAMP	BROWN-YELLOW STRIPE
918	IGN. SW. TO TRANS. NEUTRAL SW.	GREEN	998	HEADLAMP SWITCH TO HI-BEAM OF HEADLAMP	GREEN-BLACK STRIPE

1	2	3	4	5	6	7	8	9	10	11	12	13	14	15	16
	SYSTEM	PAGE		COMPONENT	PAGE LOC	COMPONENT	PAGE LOC								
A	1. CHARGE START RUN	2		ALTERNATOR.....	2 A1	LIGHTER	5 D4								
	2. EXTERIOR LIGHTING	3		AMMETER		CIGAR.....	5 D4								
	3. HEATER	4		LOOP.....	1 C6	MODULATOR									
	4. HORN	4		LOOP.....	2 A4	BREAKERLESS IGNITION.....	2 E7								
	5. ILLUMINATION LAMPS	4		BATTERY		MOTOR									
	6. IMMERSION HEATER	3		12 VOLT.....	1 B3	BLOWER.....	4 E2								
	7. POWER DISTRIBUTION	1		12 VOLT.....	2 D3	W/S WASHER PUMP.....	5 E7								
	8. PROTECTION & CONVENIENCE	5		CAPACITOR		W/S WIPER.....	5 E6								
	9. RADIO	3		RADIO IGNITION INTERFERENCE.....	2 C3	PANEL									
	10. WINDSHIELD WIPER/WASHER	5		CHOKE		FUSE.....	1 A1								
				ELECTRIC.....	2 A9	RECEIVER									
B				COIL		AM RADIO.....	3 C16								
				IGNITION.....	2 C7	REGULATOR									
				DISTRIBUTOR		ALTERNATOR.....	2 C1								
				8 CYL 302 BREAKERLESS.....	2 D7	INSTRUMENT CLUSTER VOLTAGE.....	2 B12								
C				DAVE		RELAY									
				LAMP.....	5 D2	HORN.....	4 C3								
				FLASHER		STARTER MOTOR.....	1 B4								
				EMERGENCY WARNING.....	3 B7	STARTER MOTOR.....	2 D4								
				TURN SIGNAL.....	3 B6	RESISTOR									
						BLOWER MOTOR.....	4 C2								
				GAUGE		SENDER									
				FUEL.....	2 B14	OIL PRESSURE.....	2 D13								
				OIL PRESSURE.....	2 C13	FUEL GAUGE.....	2 E14								
				WATER TEMPERATURE.....	2 C12	FUEL GAUGE.....	2 E15								
						WATER TEMPERATURE INDICATOR.....	2 D12								
				HEATER		SPEAKER									
				ENGINE BLOCK.....	3 D14	RADIO RECEIVER.....	3 E15								
				HORN.....	4 E4	STARTER									
				LAMP		MOTOR.....	2 F2								
				CLUSTER ILLUMINATION.....	4 E6	SWITCH									
				CLUSTER ILLUMINATION.....	4 D5	BACKUP LAMP.....	3 B13								
				CLUSTER ILLUMINATION.....	4 D7	DIST MODULATOR AMBIENT.....	2 E9								
				DUAL BRAKE WARNING INDICATOR.....	2 B11	DUAL BRAKE WARNING.....	2 C11								
				HDLP SW / W/S/W WASHER ILLUM.....	4 E5	FUEL TANK SELECTOR.....	2 C15								
				HEATER CONTROLS ILLUMINATION.....	4 D4	HEADLAMP.....	1 E7								
				HI BEAM INDICATOR.....	3 E2	HEADLAMP.....	3 A3								
				L.H. BACKUP.....	3 F13	HEADLAMP.....	5 B3								
				L.H. FRONT SIDE MARKER.....	3 E3	HEADLAMP DIMMER.....	3 B1								
				L.H. L0 BEAM HEAD.....	3 D1	HEATER BLOWER.....	4 B2								
				L.H. REAR SIDE MARKER.....	3 E10	HORN.....	4 E3								
				L.H. FRONT PARK & T/S.....	3 F5	IGNITION.....	1 C4								
				L.H. STOP PARK & T/S.....	3 E9	IGNITION.....	2 A6								
				L.H. TURN INDICATOR.....	3 E6	STOP LAMP.....	3 A5								
				LICENSE.....	3 E11	TURN AND EMERGENCY SIGNAL.....	3 C5								
				MAP.....	5 E3	W/S/W WASHER.....	5 B7								
				PRND ILLUMINATION.....	4 E8	VALVE									
				R.H. BACKUP.....	3 F14	DISTRIBUTOR MODULATOR.....	2 D9								
				R.H. FRONT SIDE MARKER.....	3 C3	DISTRIBUTOR VACUUM CONTROL.....	2 E10								
				R.H. L0 BEAM HEAD.....	3 D2										
				R.H. REAR SIDE MARKER.....	3 E11										
				R.H. FRONT PARK & T/S.....	3 D4										
				R.H. STOP PARK & T/S.....	3 E12										
				R.H. TURN INDICATOR.....	3 E7										

1	2	3	4	5	6	7	8	9	10	11	12	13	14	15	16
---	---	---	---	---	---	---	---	---	----	----	----	----	----	----	----

GROUND CODES
SPLICE CODES
ELECTRICAL SYSTEMS 1976 BRANCH INDEX-SYSTEM AND COMPONENT
EFFECTIVE P.C.R. SUPERSEDES DATE 7/28/75
BEPE ELECT INST MAN PAGE E61-900-INDEX SERVICE AND TRAINING MAN PAGE INDEX

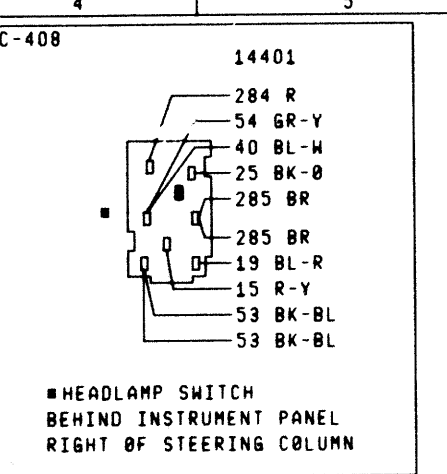
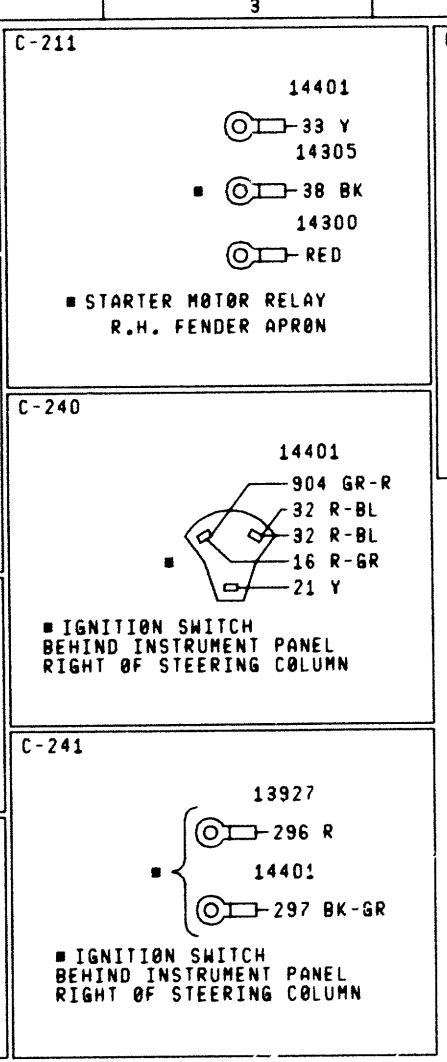
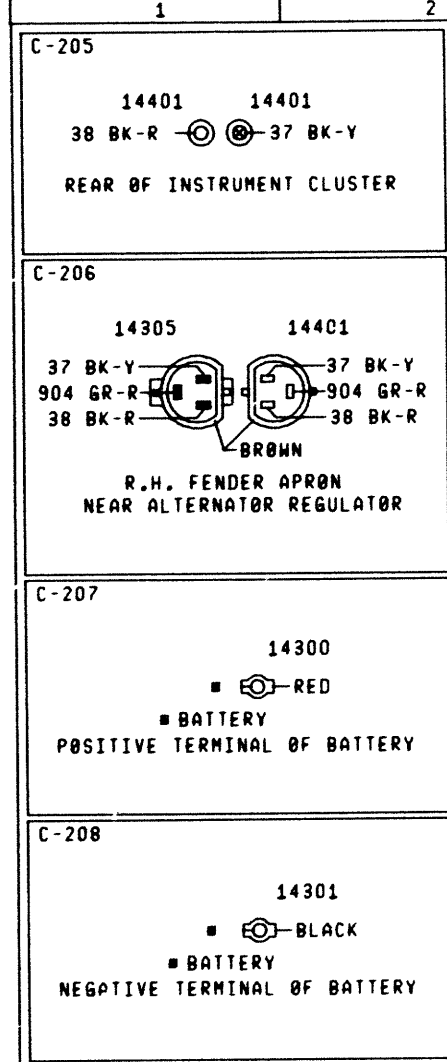
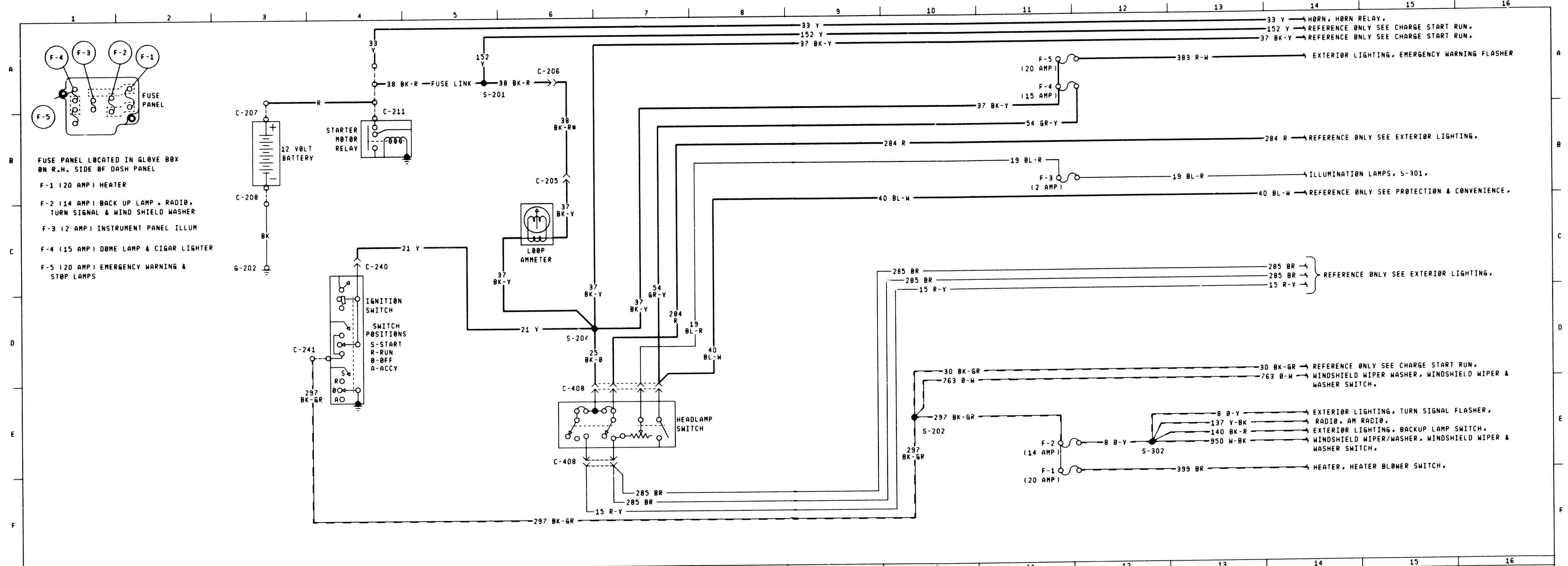

GROUND CODES	
6-202	ØN ENGINE BLOCK NEAR ALTERNATOR

SPLICE CODES	
S-201	IN 14305 NEAR STARTER MOTOR RELAY
S-202	IN 14401 NEAR TAKEOUT TO IGNITION SWITCH
S-204	IN 14401 NEAR TAKEOUT TO HEADLAMP SWITCH
S-302	IN 14401 AT TAKEOUT TO HEADLAMP SWITCH

ELECTRICAL SYSTEMS 1976 BRANCH POWER DISTRIBUTION	
EFFECTIVE P.C.R.	
SUPERSEDES	
DATE 7/28/75	BEPE ELECT INST MAN PAGE EGT-900-1
	SERVICE AND TRAINING MAN PAGE 1

1	2	3	4	5	6	7	8	9	10	11	12	13	14	15	16
SYSTEM		PAGE		COMPONENT	PAGE LOC	COMPONENT	PAGE LOC	COMPONENT	PAGE LOC	COMPONENT	PAGE LOC				
AIR CONDITIONER & HEATER		2		ACTUATOR		LAMP		RELAY		SWITCH					
CHARGE, START, RUN		3 & 4		THROTTLE	4 D14	CONTINUED...		CONTINUED...		CONTINUED...					
EXTERIOR LIGHTING		5 & 6		THROTTLE	7 E11	HEADLAMP SWITCH ILLUMINATION	2 C10	HORN SELECTOR	7 C4	COURTESY LAMP	8 E14				
HORN & SPEED CONTROL		7		ALTERNATOR	3 B2	HEATER CONTROLS ILLUMINATION	2 C13	ROOF LAMP	8 E6	DIST MODULATOR AMBIENT	4 E13				
ILLUMINATION LAMPS		2		61 AMP	3 B3	HI BEAM INDICATOR	5 E2	STARTER MOTOR	1 B7	DUAL BRAKE WARNING	4 F2				
IMMERSION HEATER		7		90 AMP	3 B5	I/P ILLUMINATION	2 C12	STARTER MOTOR	3 A8	EMERGENCY WARNING	7 E5				
POWER DISTRIBUTION		1		AMMETER	3 E6	IGN SW / W/S/W/WASHER ILLUM	2 C11	TRAILER EXTERIOR LAMPS	6 D11	EVAPORATOR THERMOSTAT	2 D5				
PROTECTION & CONVENIENCE		8		AMPLIFIER		INTERIOR SWITCH	8 D9	TRAILER EXTERIOR LAMPS	6 D12	FUEL TANK SELECTOR	4 C7				
RADIO		9		SPEED CONTROL	7 C12	L.H. BACKUP	6 E5	TRAILER EXTERIOR LAMPS	6 D13	HEADLAMP	5 B1				
WINDSHIELD WIPER/WASHER		9		BATTERY		L.H. FRONT ROOF MARKER	8 F6	WINDOW REGULATOR SAFETY	2 B4	HEADLAMP	5 B1				
				12 VOLT	1 E3	L.H. FRONT SIDE MARKER	5 D12	WINDOW REGULATOR SAFETY	2 A8	HEADLAMP DIMMER	5 C1				
				12 VOLT	1 B5	L.H. LO BEAM HEAD	5 D9	RESISTOR		HEATER BLOWER	2 C1				
				12 VOLT	3 B7	L.H. REAR ROOF MARKER	8 F8	BLOWER MOTOR	2 D1	HORN	7 B3				
				12 VOLT	3 C9	L.H. REAR SIDE MARKER	6 E3	BLOWER MOTOR	2 E3	HORN	7 B10				
				CAPACITOR		L.H. STOP PARK & T/S	5 D10	BLOWER MOTOR	2 D6	IGNITION	1 D8				
				RADIO IGNITION INTERFERENCE	3 F4	L.H. TURN INDICATOR	5 E3	SENDER		IGNITION	4 B1				
				CHOCK		LICENSE	6 E6	OIL PRESSURE	4 E3	SEAT BELT WARNING INDICATOR	8 A16				
				ELECTRIC	3 F5	MARKER SWITCH INDICATOR	8 E5	OIL PRESSURE	4 C9	SPEED CONTROL	7 A12				
				RADIO RECEIVER SUPPRESSION	4 D6	OIL PRESSURE WARNING IND	4 D3	FUEL GAUGE	4 E7	STOP LAMP	5 C5				
				COIL		PRNDL ILLUMINATION	2 C13	FUEL GAUGE	4 E10	TRANS GEAR SHIFT NEUTRAL	3 C15				
				IGNITION	3 D14	R.H. BACKUP	6 E9	FUEL GAUGE	4 E9	TRANS GEAR SHIFT NEUTRAL	5 E13				
				CONTROL		R.H. FRONT ROOF MARKER	8 F7	FUEL GAUGE	4 E10	TURN AND EMERGENCY SIGNAL	5 C3				
				AM RADIO RR SPEAKER VOLUME	9 D6	R.H. FRONT SIDE MARKER	5 D12	WATER TEMPERATURE INDICATOR	4 C8	W/S/W WASHER	9 A13				
				DISTRIBUTOR		R.H. LO BEAM HEAD	5 D10	SENSOR		VALVE					
				6 CYL 300 BREAKERLESS	3 C11	R.H. REAR ROOF MARKER	8 F8	SPEED CABLE	7 F7	DISTRIBUTOR MODULATOR	4 D13				
				8 CYL 351 BREAKERLESS	3 C12	R.H. REAR SIDE MARKER	6 E7	SOLENOID		DISTRIBUTOR VACUUM CONTROL	4 E14				
				8 CYL 460 BREAKERLESS	3 C13	R.H. STOP PARK & T/S	5 D11	A/C CLUTCH	2 F5						
				FLASHER		R.H. TURN INDICATOR	5 E4	CARB THROTTLE EMISSION CNT	4 F11						
				EMERGENCY WARNING	5 D6	SEAT BELTS WARNING INDICATOR	8 E16	EXHAUST GAS RECIRC VAC VALVE	4 D16						
				TRANSISTORIZED	8 C7	WATER TEMP WARNING IND	4 D3	FUEL TANK SELECTOR AND VALVE	4 F7						
				TURN SIGNAL	5 C6	LIGHTER		SPEAKER							
				GAUGE		CIGAR	8 D3	RADIO RECEIVER	9 E1						
				FUEL	4 A10	MODULATOR		RADIO RECEIVER	9 E2						
				OIL PRESSURE	4 A9	IGNITION BREAKERLESS	3 F13	RADIO RECEIVER	9 E3						
				WATER TEMPERATURE	4 A8	MOTOR		RADIO RECEIVER	9 E4						
				GOVERNOR		BLOWER	2 F2	RADIO RECEIVER	9 E5						
				W/S WIPER	9 C13	BLOWER	2 E4	RADIO RECEIVER	9 E5						
				HEATER		BLOWER	2 E7	RADIO RECEIVER	9 E7						
				ENGINE BLOCK	7 E15	STARTER	3 E9	RADIO RECEIVER	9 E8						
				HORN		W/S WIPER	9 F12	SPEED							
				LOW PITCH	7 D2	PANEL		SENSOR SWITCH HORN	7 C5						
				LOW PITCH	7 F1	FUSE	1 B2	STARTER							
				LOW PITCH	7 F2	RECEIVER		MOTOR	3 E8						
				LOW PITCH	7 F2	AM RADIO	2 C15	SWITCH							
				LAMP		AM RADIO	9 B5	A/C CONTROL	2 B3						
				ALTERNATOR WARNING INDICATOR	4 E5	AM/FM/MPX RADIO	9 B9	A/C CONTROL	2 C8						
				CARGO	8 F3	STEREO TAPE/ AM/FM/MPX RADIO	2 C16	A/C MODE	2 B6						
				DOME	8 F2	REGULATOR		BACKUP LAMP	5 E15						
				DUAL BRAKE WARNING INDICATOR	4 D2	ALTERNATOR	3 E2	COURTESY LAMP	8 B4						
				HDLP/IGN/ W/S/W/WASHER ILLUM	2 C9	INSTRUMENT CLUSTER VOLTAGE	4 E6	COURTESY LAMP	8 E4						
						RELAY		COURTESY LAMP	8 B5						
						ACCESSORY SAFETY	1 E4	COURTESY LAMP	8 C9						
						ACCESSORY SAFETY	3 C9	COURTESY LAMP	8 B10						
						HORN	7 A2	COURTESY LAMP	8 E10						
								COURTESY LAMP	8 E11						
								COURTESY LAMP	8 E13						

GROUND CODES
SPLICE CODES
ELECTRICAL SYSTEMS 1976 ECNOLINE INDEX-SYSTEM AND COMPONENT
EFFECTIVE P.C.R. SUPERSEDES DATE 8-4-75
BEPE ELECT INST MAN PAGE E6U-900-INDEX SERVICE AND TRAINING MAN PAGE INDEX

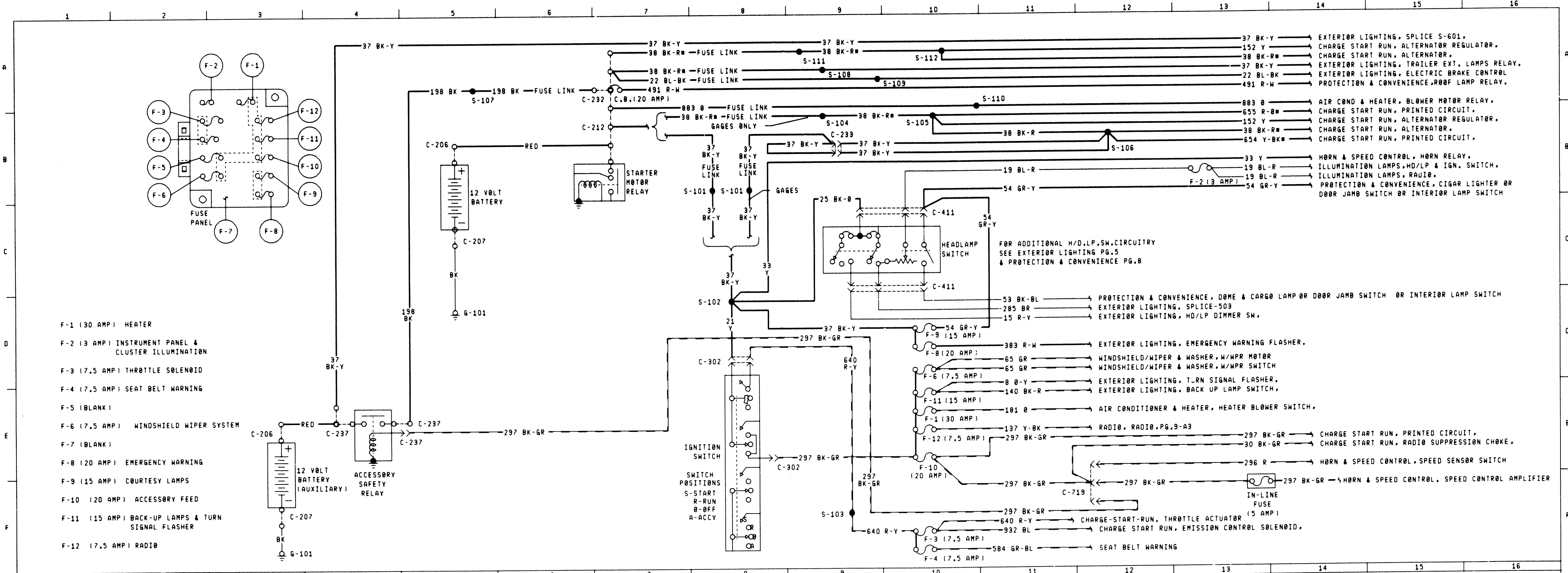

- F-1 (30 AMP) HEATER
- F-2 (3 AMP) INSTRUMENT PANEL & CLUSTER ILLUMINATION
- F-3 (7.5 AMP) THROTTLE SOLENOID
- F-4 (7.5 AMP) SEAT BELT WARNING
- F-5 (BLANK)
- F-6 (7.5 AMP) WINDSHIELD WIPER SYSTEM
- F-7 (BLANK)
- F-8 (20 AMP) EMERGENCY WARNING
- F-9 (15 AMP) COURTESY LAMPS
- F-10 (20 AMP) ACCESSORY FEED
- F-11 (15 AMP) BACK-UP LAMPS & TURN SIGNAL FLASHER
- F-12 (17.5 AMP) RADIO

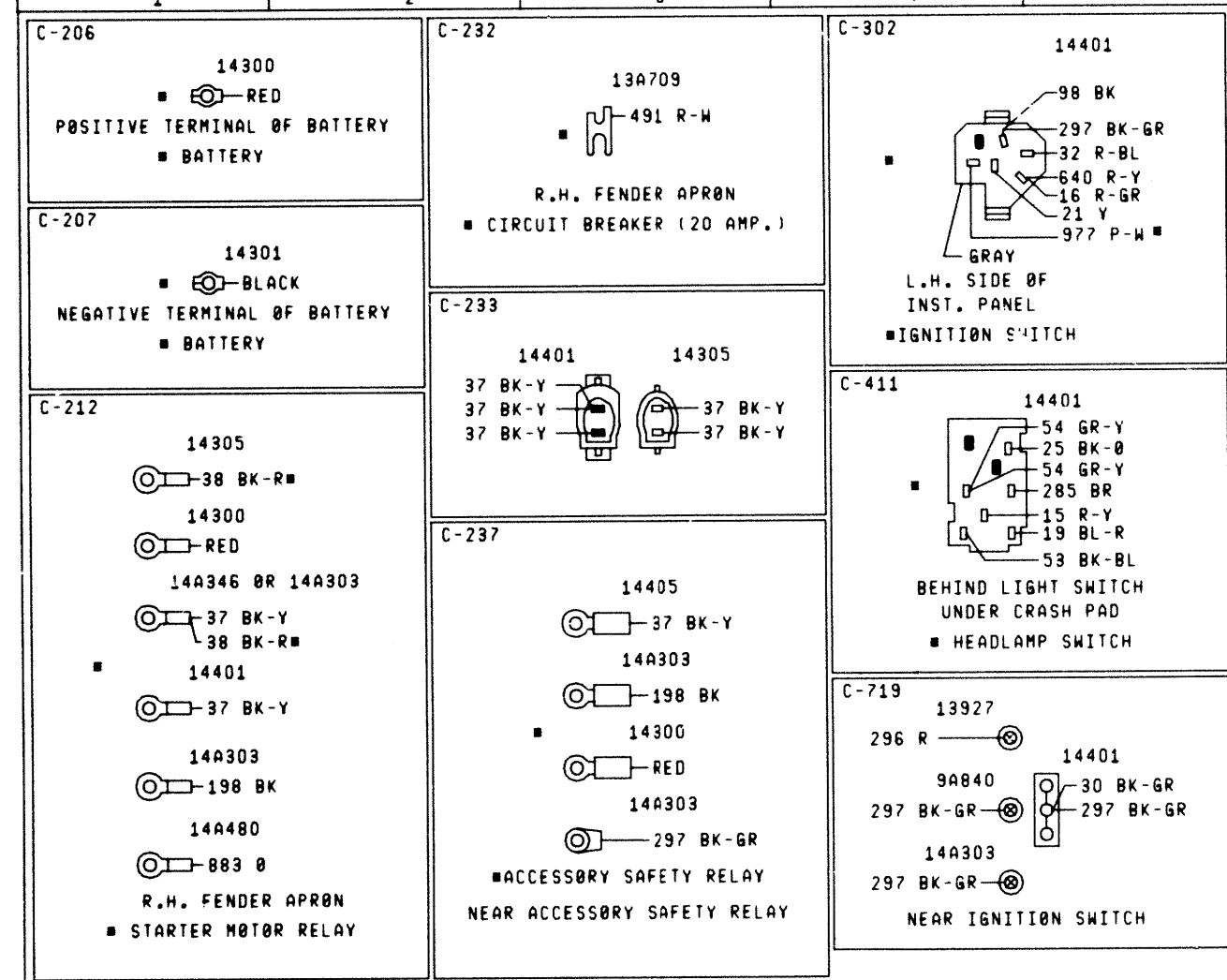

GROUND CODES	
G-101	EYELET ATTACHED TO R.H. SIDE ENGINE BLOCK

SPLICE CODES	
S-101	IN 14401 NEAR STARTING MOTOR RELAY
S-102	IN 14401 NEAR T/O TO EMERGENCY WARNING FLASHER
S-103	IN 14401 NEAR I/P GROUND R.H. SIDE
S-104	IN 14305 NEAR STARTING MOTOR
S-105	IN 14305 NEAR T/O TO STARTING MOTOR RELAY
S-106	IN 14305 NEAR T/O TO 14401 ASSY
S-107	IN 14A303 NEAR STARTING MOTOR RELAY
S-108	IN 14A303 OR 14A346 NEAR STARTING MOTOR RELAY
S-109	IN 14A303 OR 14A346 NEAR STARTING MOTOR RELAY
S-110	IN 14A480 NEAR STARTING MOTOR RELAY
S-111	IN 14305 NEAR STARTING MOTOR RELAY
S-112	IN 14305 NEAR T/O TO STARTER MOTOR RELAY

ELECTRICAL SYSTEMS 1976 ECONOLINE POWER DISTRIBUTION	
EFFECTIVE P.C.R.	
SUPERSEDES	
DATE 8-4-75	BEPE ELECT INST MAN PAGE EGU-900-1 SERVICE AND TRAINING MAN PAGE 1

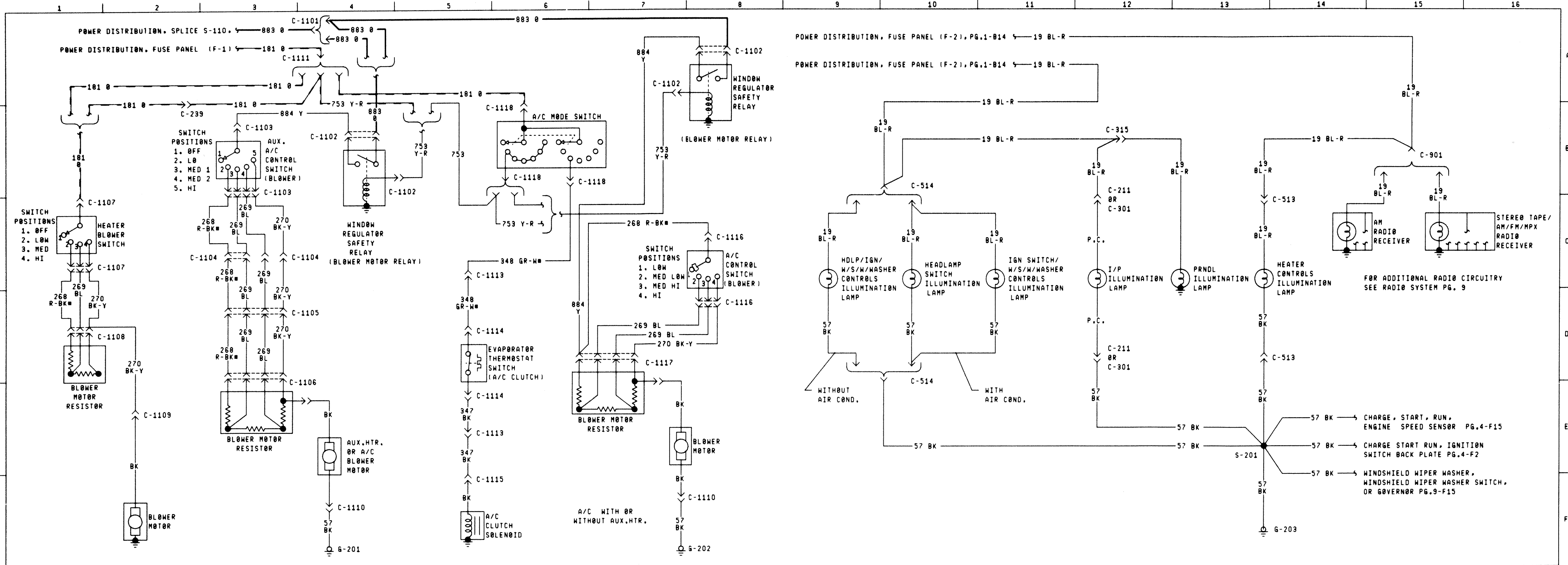

- C-1113 19A885 19A885
347 BK 347 BK
348 GR-W 348 GR-W
GREEN
NEAR T/O BLOWER MOTOR GROUND
- C-1114 19A885
EVAPORATOR THERMOSTAT SWITCH 348 GR-W
347 BK
R.H. SIDE BEHIND INST. PANEL
- C-1115 19A885
BK 347 BK
NEAR A/C COMPRESSOR IN ENGINE COMPARTMENT
PART OF A/C CLUTCH SOLENOID
- C-1116 19A885
HEATER-A/C BLOWER SWITCH 270 BK-Y
269 BL
268 R-BK
269 BL
BEHIND A/C CONTROLS
- C-1117 19A885
A/C BLOWER MOTOR RESISTOR 269 BL
884 Y
268 R-BK
270 BK-Y
269 BL
PART OF BLOWER MOTOR
R.H. SIDE STEERING COLUMN
- C-1118 19A885
A/C MODE SWITCH 753 Y-R
181 Ø
348 GR-W
R.H. SIDE STEERING COLUMN

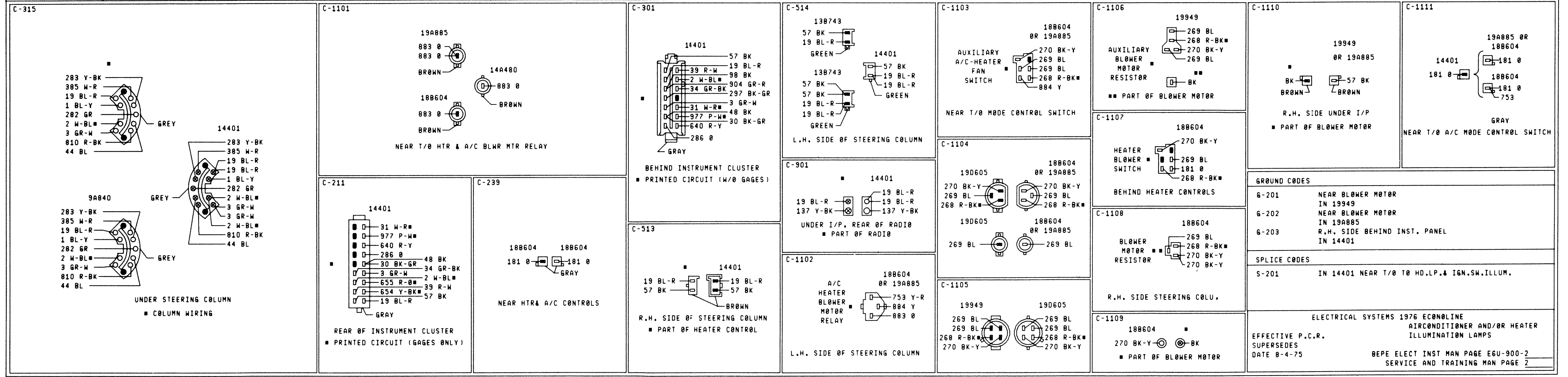

1	2	3	4	5	6	7	8	9	10	11	12	13	14	15	16
				COMPONENT	PAGE LOC	COMPONENT	PAGE LOC	COMPONENT	PAGE LOC	COMPONENT	PAGE LOC				
				ACTUATOR THROTTLE.....2 E14 THROTTLE.....6 F13 ALTERNATOR 61 AMP.....1 B2 AMMETER.....1 D4 AMMETER.....1 D4 AMPLIFIER SPEED CONTRL.....6 D13 BATTERY 12 VOLT.....1 D6 12 VOLT.....8 E9 12 VOLT.....9 D1 12 VOLT.....9 D2 CAPACITOR RADIO IGNITION INTERFERENCE.....1 F3 CHOKE ELECTRIC.....1 D2 RADIO RECEIVER SUPPRESSION.....2 C4 COIL IGNITION.....1 D12 DISTRIBUTOR 6 CYL BREAKERLESS.....1 C10 8 CYL 302/460 BREAKERLESS.....1 C11 8 CYL 351/400 BREAKERLESS.....1 C12 FLASHER EMERGENCY WARNING.....5 E16 TURN SIGNAL.....5 D14 GAUGE FUEL.....2 C5 FUEL.....2 C7 OIL PRESSURE.....2 C4 OIL PRESSURE.....2 C6 WATER TEMPERATURE.....2 C5 WATER TEMPERATURE.....2 C7 GOVERNOR W/S WIPER.....3 C12 HEATER ENGINE BLOCK.....4 C7 ENGINE BLOCK.....4 E7 ENGINE BLOCK.....4 E8 HORN HIGH PITCH.....6 E8 LOW PITCH.....6 E7 LAMP 4 WHEEL DRIVE INDICATOR.....3 D15 ALTERNATOR WARNING INDICATOR.....2 C3 CARBON SHELL SWITCH.....1 D5 CLUSTER ILLUMINATION.....4 E11 CLUSTER ILLUMINATION.....4 E12 CLUSTER ILLUMINATION (2).....4 D10	LAMP CONTINUED... DOME.....4 E14 DOME.....4 E14 DUAL BRAKE WARNING INDICATOR.....1 C14 W/S WASHER PUMP.....3 E12 W/S WIPER.....3 E11 GLOVE BOX SWITCH.....5 E1 HDLP SW / W/S/W/WASHER ILLUM.....4 E11 HEATER CONTROLS ILLUMINATION.....4 E9 HI BEAM INDICATOR.....5 F5 HI BEAM INDICATOR.....5 F5 HI BEAM INDICATOR.....5 F5 I/P ASH TRAY ILLUMINATION.....3 C15 L.H. BACKUP.....8 E6 L.H. BACKUP.....8 E6 L.H. FRONT MARKER.....7 D5 L.H. FRONT SIDE MARKER.....5 E9 L.H. FRONT SIDE MARKER.....7 D5 L.H. LB BEAM HEAD.....5 E4 L.H. MIRROR MARKER.....7 F1 L.H. REAR MARKER.....7 E5 L.H. REAR SIDE MARKER.....7 E5 L.H. SIDE MARKER.....7 F9 L.H. SIDE MARKER.....7 E11 L.H. SIDE MARKER.....7 E11 L.H. STOP PARK & T/S.....5 E3 L.H. STOP PARK & T/S.....7 E9 L.H. TURN INDICATOR.....3 F9 L.H. TURN INDICATOR.....3 F9 LICENSE.....7 F12 LICENSE.....7 E12 OIL PRESSURE WARNING IND.....2 C2 PARKING LAMP SWITCH ILLUM.....4 C12 PRNDL ILLUMINATION.....4 D10 PRNDL ILLUMINATION.....4 C11 R.H. BACKUP.....8 E8 R.H. BACKUP.....8 E7 R.H. FRONT MARKER.....7 D7 R.H. FRONT SIDE MARKER.....5 E7 R.H. FRONT SIDE MARKER.....7 D7 R.H. LB BEAM HEAD.....5 E6 R.H. MIRROR MARKER.....7 F2 R.H. REAR MARKER.....7 E7 R.H. REAR SIDE MARKER.....7 E7 R.H. SIDE MARKER.....7 E3 R.H. SIDE MARKER.....7 E3 R.H. SIDE MARKER.....7 E14 R.H. FRONT PARK & T/S.....5 E8 R.H. STOP PARK & T/S.....7 E10 R.H. STOP PARK & T/S.....7 E14 R.H. STOP PARK & T/S.....7 E15 R.H. TURN INDICATOR.....5 F10 R.H. TURN INDICATOR.....5 F11 REAR MARKER.....7 F7 ROOF MARKER.....7 E3 SEAT BELTS WARNING INDICATOR.....3 E1 UTILITY.....4 F15 LIGHTER CIGAR.....5 F2 MODULATOR IGNITION BREAKERLESS.....1 F11	MOTOR BLOWER.....4 E2 BLOWER.....4 E6 STARTER.....1 F7 W/S WASHER PUMP.....3 E12 W/S WIPER.....3 E11 PANEL FUSE.....INDEX B1 RECEIVER AM RADIO.....3 C14 AM/FM/MPX RADIO.....3 C14 REGULATOR ALTERNATOR.....1 E1 INSTRUMENT CLUSTER VOLTAGE.....2 C5 INSTRUMENT CLUSTER VOLTAGE.....2 C7 RELAY ACCESSORY SAFETY.....4 D3 ACCESSORY SAFETY.....9 C3 HORN.....6 D5 MARKER LAMPS.....7 C4 MARKER LAMPS.....9 B3 STARTER MOTOR.....1 C7 STARTER MOTOR.....8 D9 STARTER MOTOR.....8 C1 TRAILER EXTERIOR LAMPS.....8 E13 TRAILER EXTERIOR LAMPS.....8 E16 TRAILER EXTERIOR LAMPS.....8 E15 RESISTOR BLOWER MOTOR.....4 D2 BLOWER MOTOR.....4 E5 SENDER OIL PRESSURE.....2 F4 FUEL GAUGE.....2 E6 FUEL GAUGE.....3 E4 FUEL GAUGE.....3 E4 FUEL GAUGE.....3 E3 WATER TEMPERATURE INDICATOR.....2 F5 SENSOR SPEED CABLE.....6 F11 SOLENOID A/C CLUTCH.....4 F4 CARB THROTTLE EMISSION CONT.....2 C3 EXHAUST GAS RECIRC VAC VALVE.....2 E16 FUEL TANK SELECTOR AND VALVE.....3 F3 SPEAKER RADIO RECEIVER.....3 F13 RADIO RECEIVER.....3 F14 RADIO RECEIVER.....3 E15 SWITCH A/C CONTROL.....4 C2 A/C MODE.....4 B4 BACKUP LAMP.....8 B6 BACKUP LAMP.....8 B6 COURTESY LAMP.....4 C16 COURTESY LAMP.....4 D15	SWITCH CONTINUED... DIST MODULATOR AMBIENT.....2 D11 DISTRIBUTOR MODULATOR VALVE.....2 E13 DOOR OPEN WARNING LAMP.....3 F15 DUAL BRAKE WARNING.....1 F14 EVAPORATOR THERMOSTAT.....4 D4 FUEL TANK SELECTOR.....3 C3 HEADLAMP.....4 B13 HEADLAMP DIMMER.....5 C5 HEATER BLOWER.....4 C5 HORN.....6 E6 HORN.....6 C14 HORN.....6 C14 IGNITION.....3 D16 MARKER LAMPS.....3 D16 OIL PRESSURE.....2 F2 SEAT BELT RETRACTOR.....3 E1 SEAT BELT WARNING INDICATOR.....3 C1 SPEED CONTRL.....6 C16 STOP LAMP.....6 D3 STOP LAMP.....6 D3 TRANS GEAR SHIFT NEUTRAL.....8 C2 TURN AND EMERGENCY SIGNAL.....3 D13 UTILITY LAMP (CARBON).....4 D15 W/S/W WASHER.....3 C10 VALVE DISTRIBUTOR MODULATOR.....2 D10 DISTRIBUTOR VACUUM CONTROL.....2 D12 W/S/W WASHER SWITCH.....3 B12								

GROUND CODES
SPLICE CODES
ELECTRICAL SYSTEMS 1976 F-100-350 SERIES INDEX-SYSTEM AND COMPONENT EFFECTIVE P.C.R. SUPERSEDES DATE 8-6-75
BEPE ELECT INST MAN PAGE E61-900-INDEX SERVICE AND TRAINING MAN PAGE INDEX

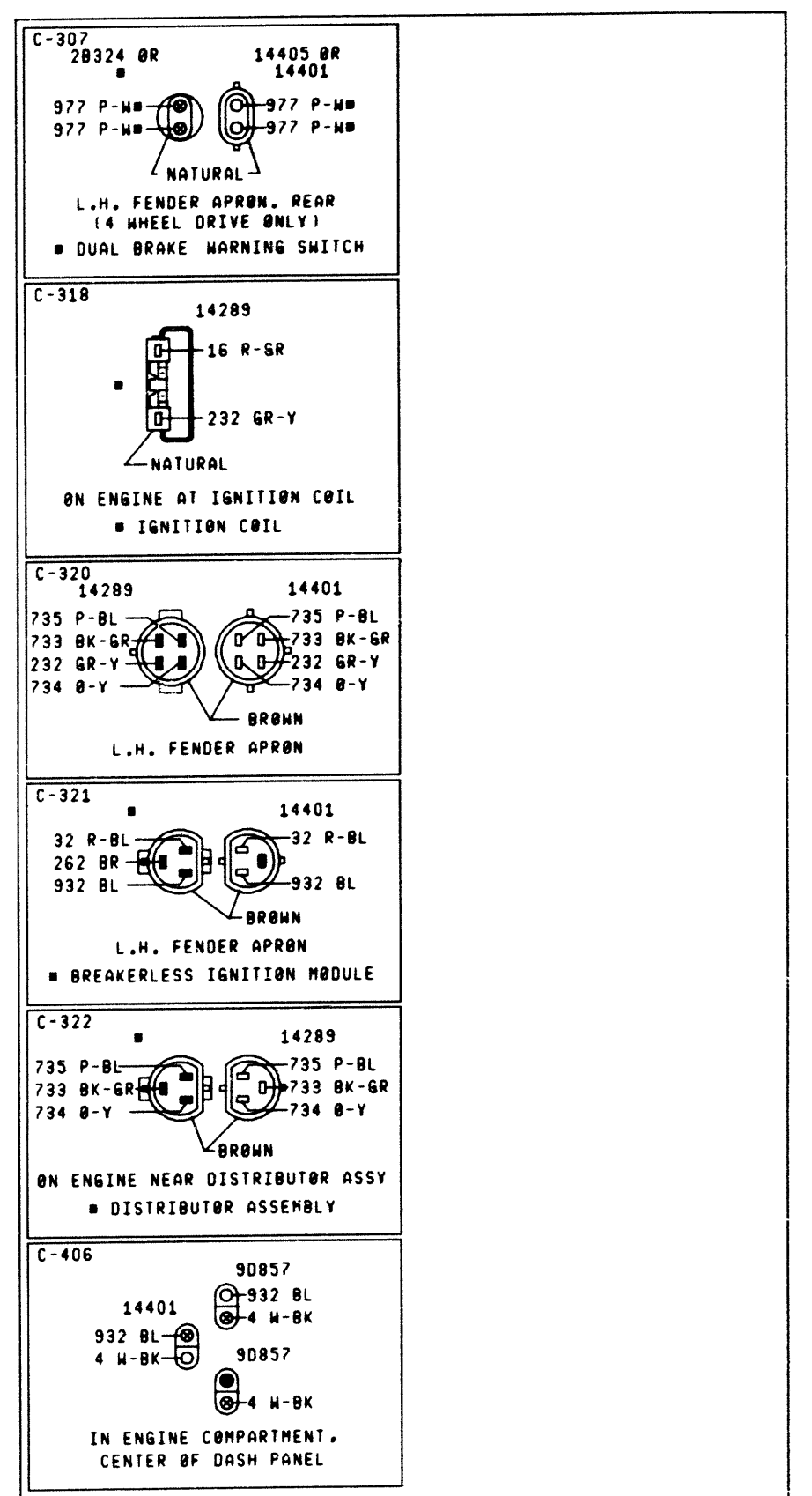
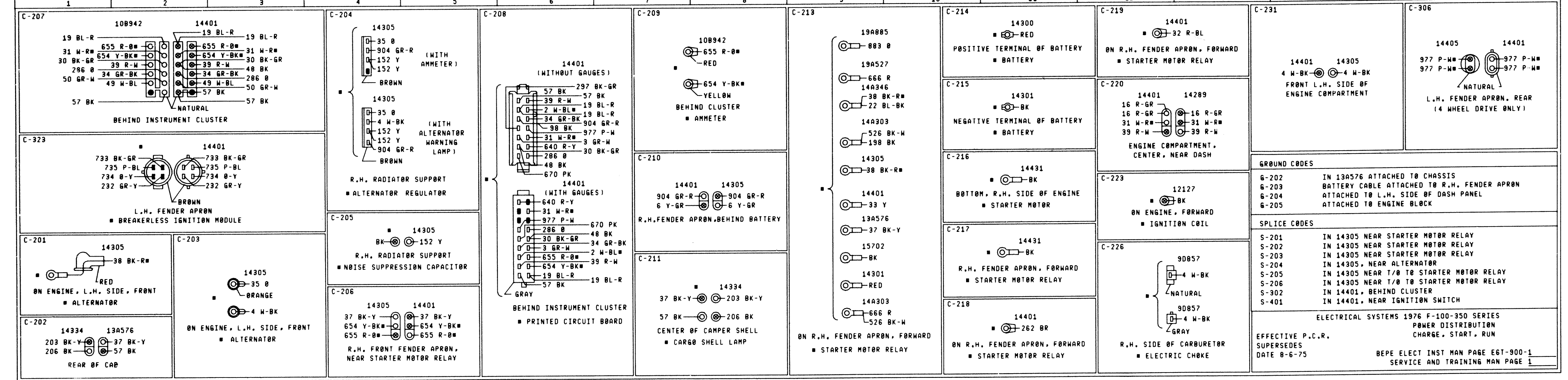
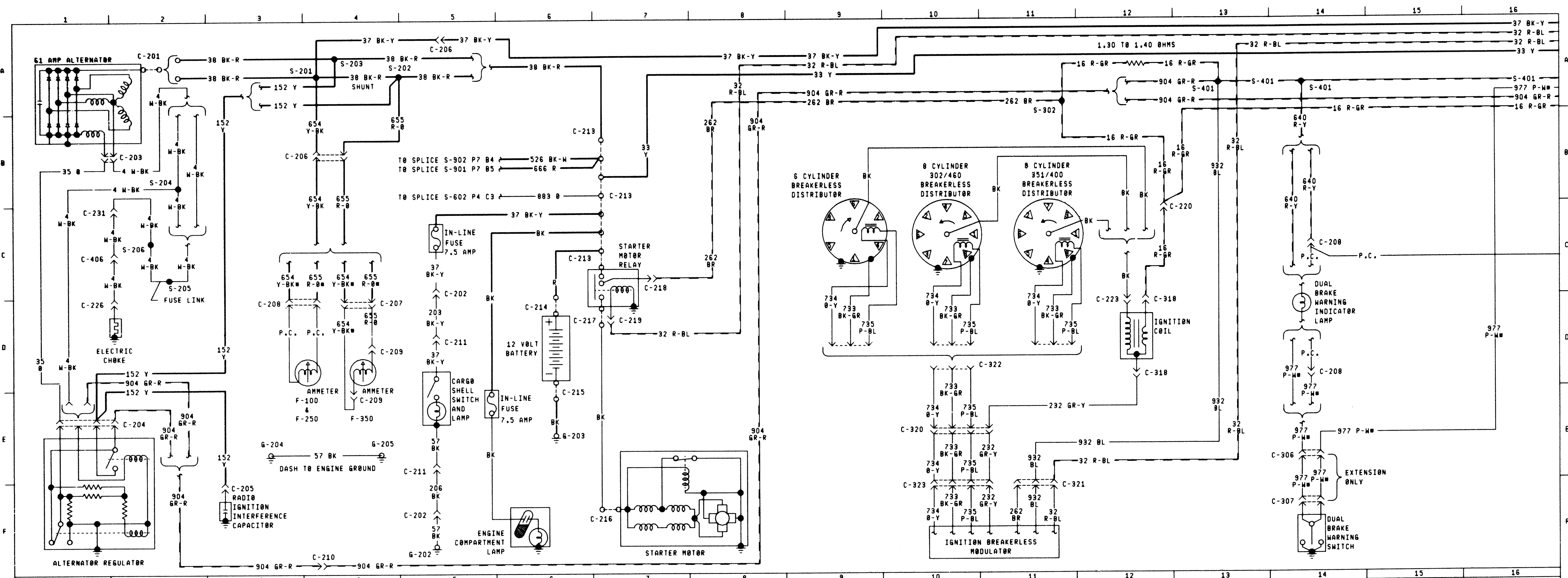

GROUND CODES

G-202 IN 13A576 ATTACHED TO CHASSIS
 G-203 BATTERY CABLE ATTACHED TO R.H. FENDER APRON
 G-204 ATTACHED TO L.H. SIDE OF DASH PANEL
 G-205 ATTACHED TO ENGINE BLOCK

SPLICE CODES

S-201 IN 14305 NEAR STARTER MOTOR RELAY
 S-202 IN 14305 NEAR STARTER MOTOR RELAY
 S-203 IN 14305 NEAR STARTER MOTOR RELAY
 S-204 IN 14305, NEAR ALTERNATOR
 S-205 IN 14305 NEAR T/O TO STARTER MOTOR RELAY
 S-206 IN 14305 NEAR T/O TO STARTER MOTOR RELAY
 S-302 IN 14401, BEHIND CLUSTER
 S-401 IN 14401, NEAR IGNITION SWITCH

ELECTRICAL SYSTEMS 1976 F-100-350 SERIES
 POWER DISTRIBUTION CHARGE, START, RUN
 EFFECTIVE P.C.R. SUPersedES DATE 8-6-75
 BEPE ELECT INST MAN PAGE EST-900-1
 SERVICE AND TRAINING MAN PAGE 1

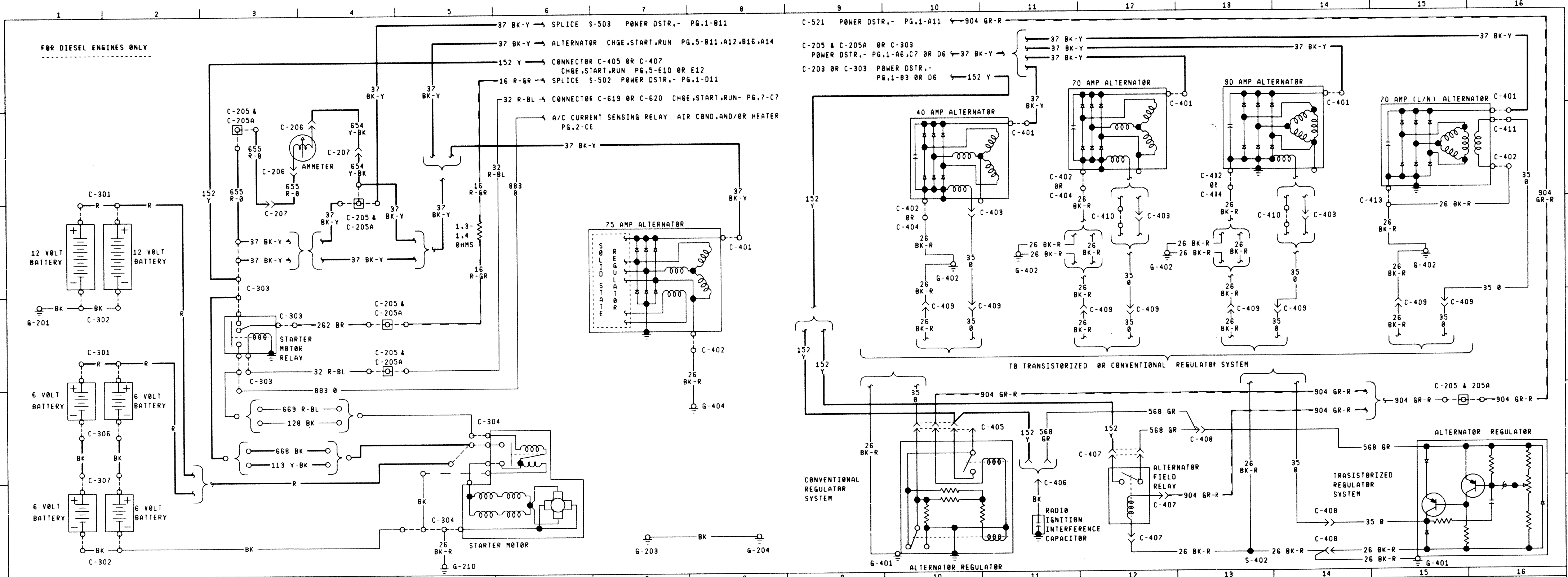

<p>C-205</p> <p>JUNCTION BLOCK</p> <p>(19B573) BK → 359 BK-W (19A885) (9A281 OR 14305) 596 BK → 596 BK (9A342) (9A281 OR 14305) 597 R → 597 R (9A342) (9A281 OR 14305) 787 R-BK → 787 R-BK (9A342) (14672) 482 BL-Y → 482 BL-Y (14401) 482 BL-Y → 13 R-BK (14401) (14290) 12 GR-BK → 12 GR-BK (14401) (14290) 11 BK-Y → 11 BK-Y (14401)</p> <p>FOR CONTINUATION SEE C-205A IN ENGINE COMPARTMENT, ON L.H. SIDE OF DASH</p>	<p>C-206</p> <p>108942 AMMETER = 654 Y-BK BEHIND CLUSTER</p>	<p>C-302</p> <p>14301 BATTERY = BK AT BATTERY</p>	<p>C-304</p> <p>11A003 26 BK-R 668 BK 663 R-BL</p> <p>14305 113 Y-BK 128 BK</p> <p>14301 BK BK</p> <p>14300 R</p>	<p>C-401</p> <p>14305 37 BK-Y RED 14305 37 BK-Y 14305 37 BK-Y</p> <p>ON ENGINE, L.H. SIDE, FRONT ALTERNATOR</p>	<p>C-404</p> <p>14305 26 BK-R</p> <p>ON ENGINE, L.H. SIDE, FRONT ALTERNATOR</p>	<p>C-408</p> <p>14398 568 GR 568 GR 35 Ø 26 BK-R 26 BK-R</p> <p>R.H. SIDE OF DASH PANEL, IN ENGINE COMPARTMENT ALTERNATOR REGULATOR</p>	<p>C-411</p> <p>14305 35 Ø 14305 35 Ø</p> <p>ALTERNATOR FORWARD L.H. SIDE OF ENGINE</p>	
<p>C-205A</p> <p>JUNCTION BLOCK</p> <p>14401 (14398) 904 GR-R → 904 GR-R (14398) 37 BK-Y → 37 BK-Y (14305) 37 BK-Y → 654 Y-BK (14398) 655 R-Ø → 655 R-Ø</p> <p>(9E724 OR 14398) 32 R-BL → 32 R-BL (9E306 OR 14305) 69 R-GR → 69 R-GR (12336) 853 R-GR → 16 R-GR (14398) 262 BR → 16 R-GR</p> <p>FOR CONTINUATION SEE C-205 IN ENGINE COMPARTMENT, ON DASH PANEL, L.H. SIDE</p>	<p>C-207</p> <p>14401 655 R-Ø 654 Y-BK 39 R-W 19 BL-R 31 W-R 30 BK-GR 286 Ø 50 GR-W 57 BK 34 GR-BK 49 W-BL</p> <p>108942 655 R-Ø 654 Y-BK 39 R-W 19 BL-R 31 W-R 30 BK-GR 286 Ø 50 GR-W 57 BK 34 GR-BK 49 W-BL</p> <p>NATURAL BEHIND INSTRUMENT CLUSTER</p>	<p>C-303</p> <p>14398 37 BK-Y 655 R-Ø 152 Y 32 R-BL 262 BR 11A103</p> <p>669 R-BL 668 BK 32 R-BL 37 BK-Y</p> <p>14305 113 Y-BK 128 BK</p> <p>19A885 883 Ø</p> <p>STARTER MOTOR RELAY R.H. SIDE OF ENGINE COMPARTMENT</p>	<p>C-306</p> <p>14304 BATTERY = BK AT BATTERY</p>	<p>C-402</p> <p>14305 26 BK-R 14305 26 BK-R</p> <p>ALTERNATOR FORWARD L.H. SIDE OF ENGINE</p>	<p>C-406</p> <p>14398 152 Y 14398 568 GR</p> <p>R.H. SIDE OF DASH PANEL, ON ALTERNATOR REGULATOR NOISE SUPP. CAPACITOR CONVENTIONAL IGNITION TRANSISTORIZED IGNITION</p>	<p>C-409</p> <p>14305 26 BK-R 14398 35 Ø 35 Ø</p> <p>IN ENGINE COMPARTMENT, R.H. SIDE OF DASH PANEL, NEAR STARTER MOTOR RELAY</p>	<p>C-413</p> <p>14305 26 BK-R 26 BK-R</p> <p>ALTERNATOR FORWARD L.H. SIDE OF ENGINE</p>	
<p>GROUND CODES</p> <p>G-201 IN 14301, AT FRAME SIDEMEMBER AT BATT TRAY G-203 IN 14303, ATTACHED TO ENGINE BLOCK G-204 IN 14303, ATTACHED TO DASH PANEL G-210 IN 11A003 ATTACHED TO DASH PANEL GROUND G-401 IN 14398, AT ALT. REGULATOR MOUNTING SCREW G-402 IN 14305, AT ALTERNATOR MOUNTING BRACKET G-404 IN 14305 ATTACHED TO DASH PNL.GROUND</p>								<p>SPLICE CODES</p> <p>S-402 IN 14398, NEAR TAKEOUT TO ALTERNATOR REGULATOR</p>
<p>ELECTRICAL SYSTEMS 1976 L-SER (CITY DEL) CHARGE, START, RUN</p> <p>EFFECTIVE P.C.R. SUPERSEDES DATE 10-30-75</p>								<p>TRB ELECT INST MAN PAGE ESH-900-5 SERVICE AND TRAINING MAN PAGE 5</p>

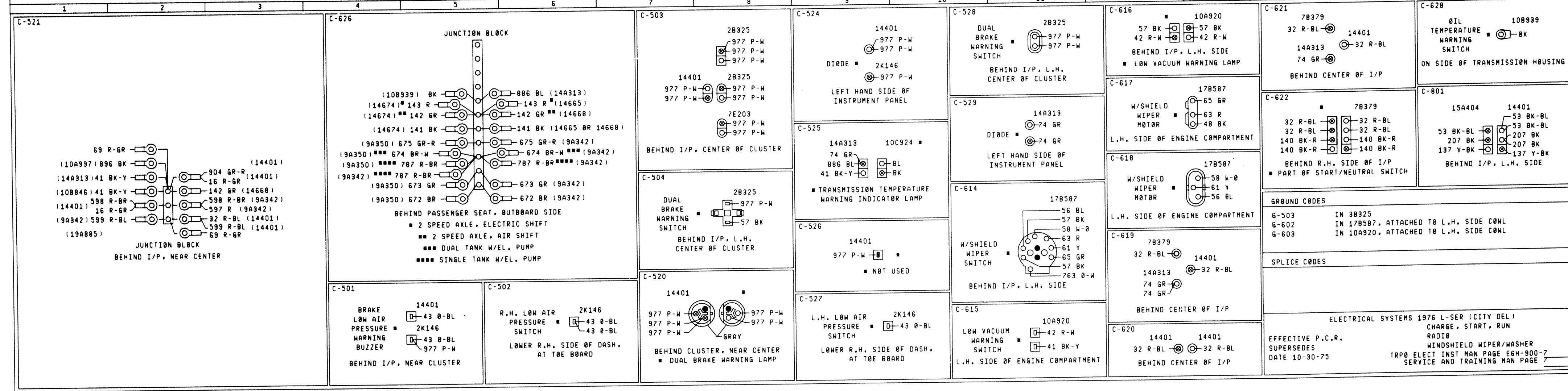
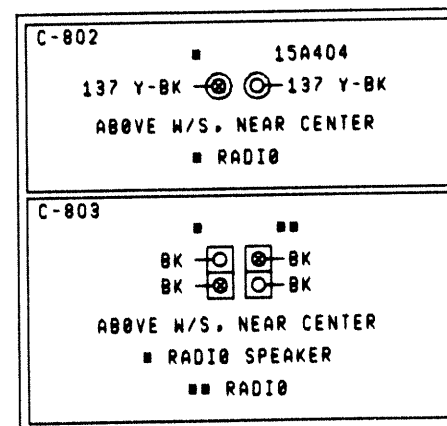
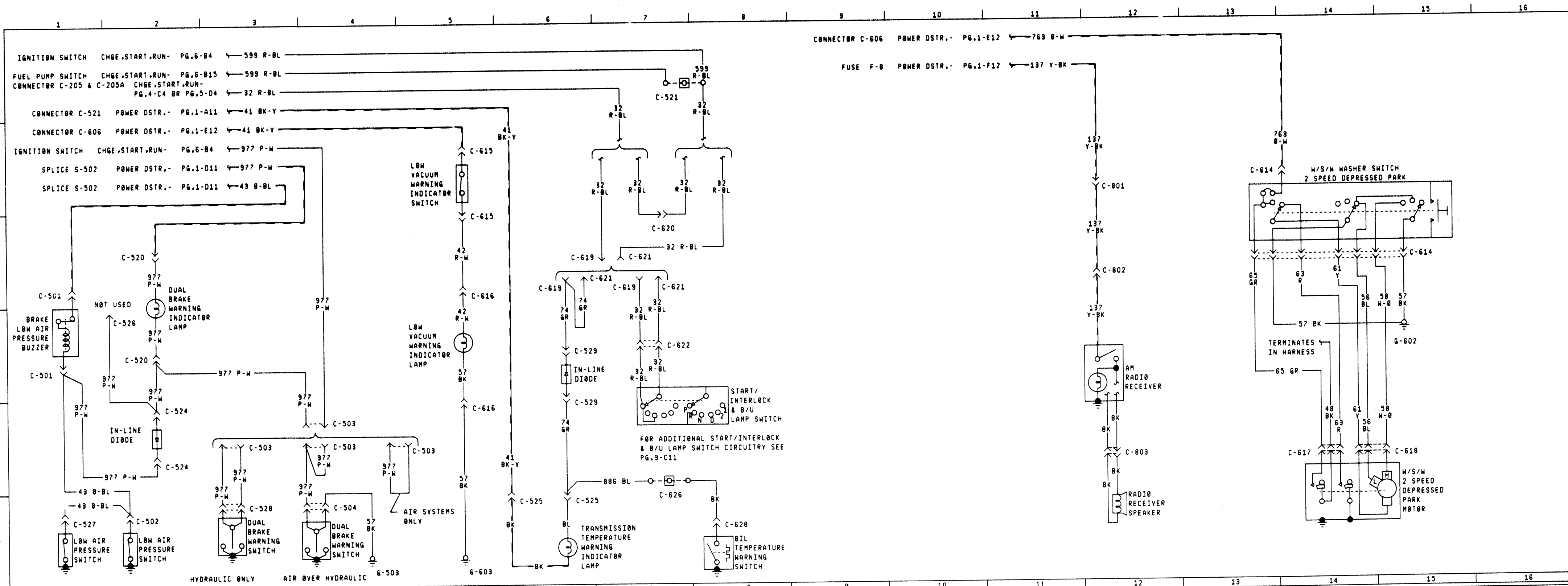

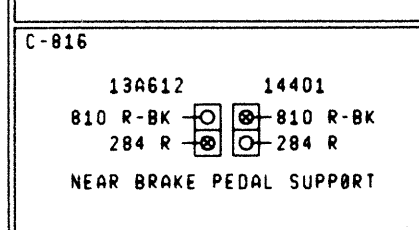
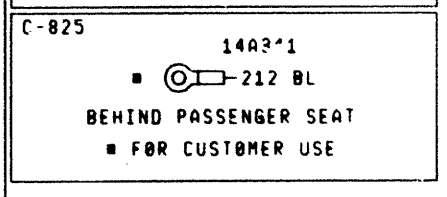
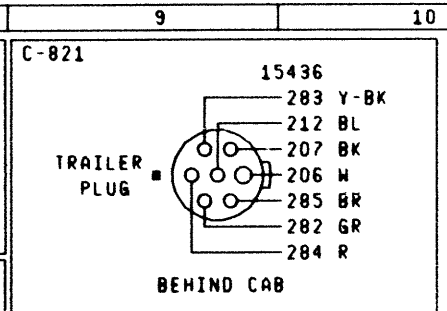
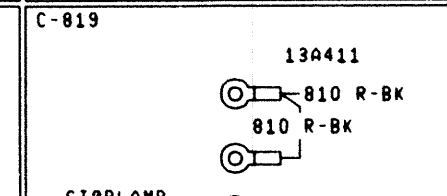
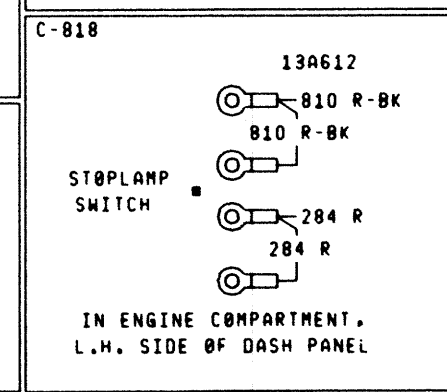
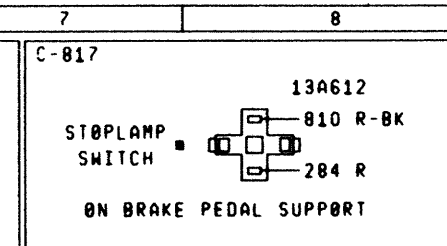
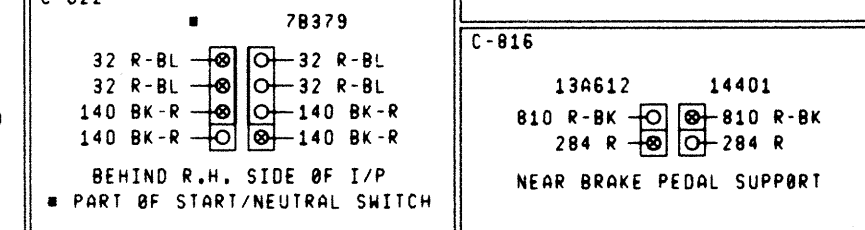
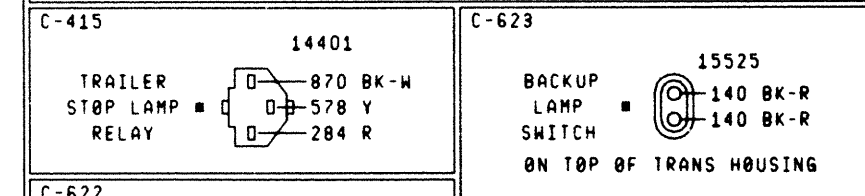
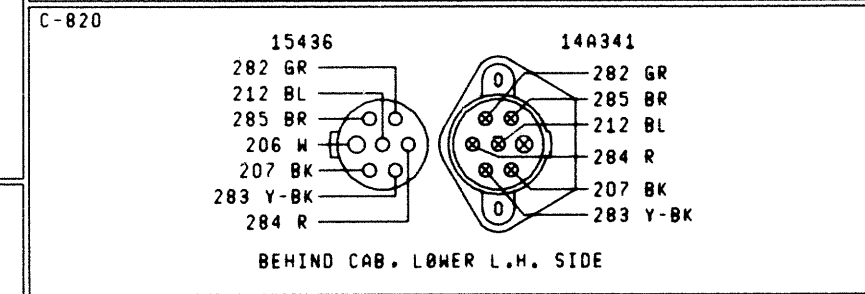
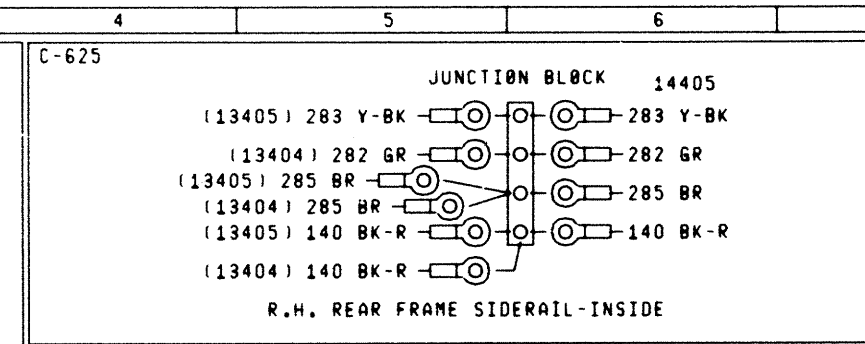
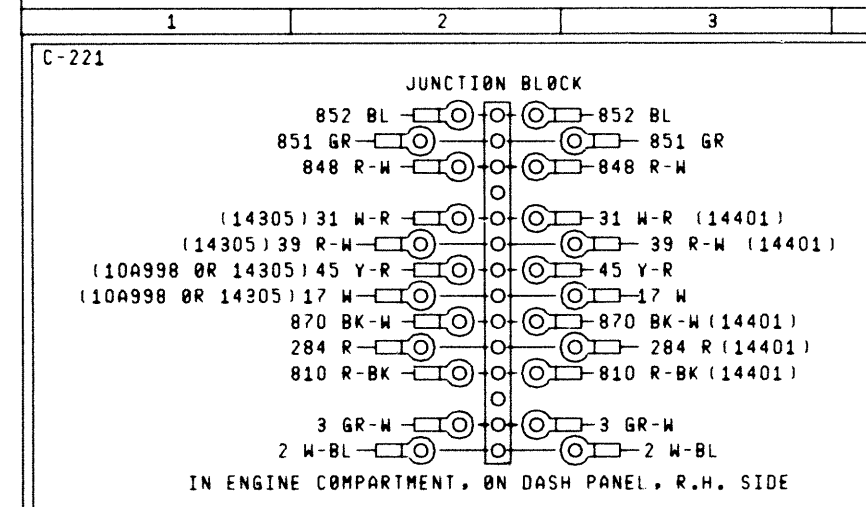
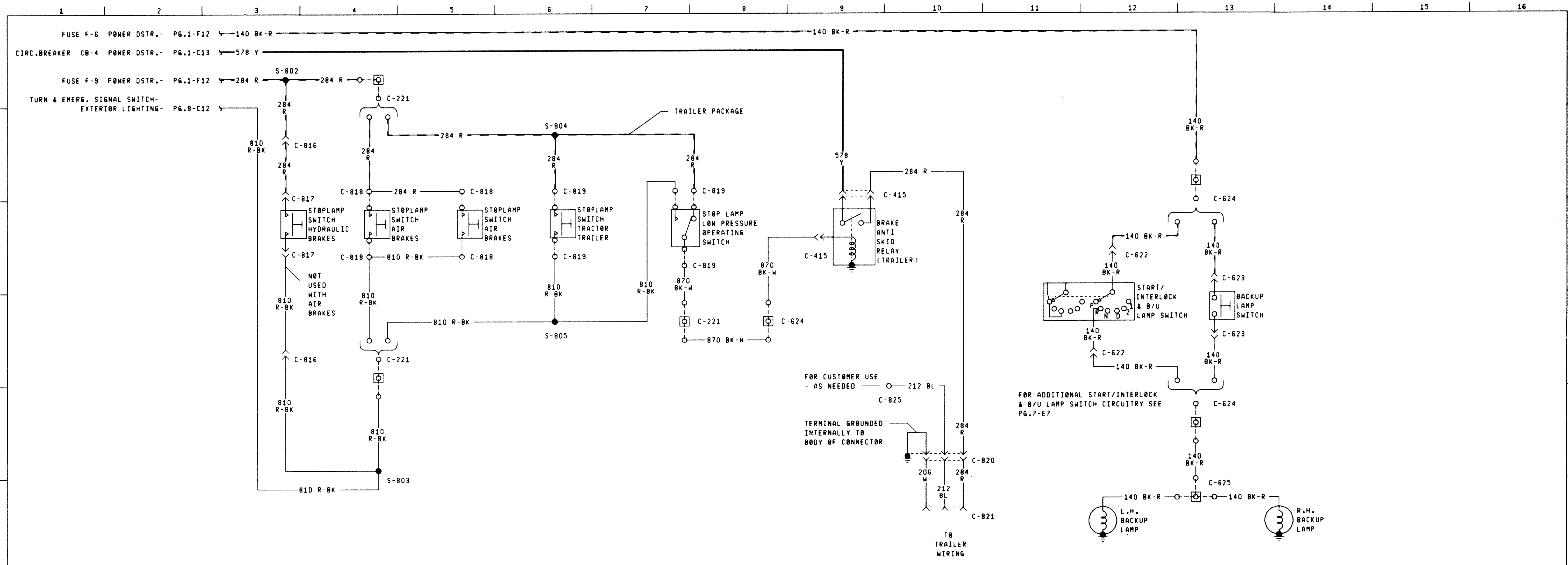

GROUND CODES	
SPLICE CODES	
S-802	IN 14401, NEAR TAKEOUT TO STOP LAMP SWITCH
S-803	IN 14401, NEAR TAKEOUT TO STOP LAMP SWITCH
S-804	IN 13A411, NEAR TAKEOUT TO EMERG. TRR. ST/LP SW.
S-805	IN 13A411, NEAR TAKEOUT TO JUNCTION BLOCK
ELECTRICAL SYSTEMS 1976 L-SER (CITY DEL) EXTERIOR LIGHTING	
EFFECTIVE P.C.R. SUPersedES DATE 10-30-75	
TRPB ELECT INST MAN PAGE E6H-900-3 SERVICE AND TRAINING MAN PAGE 5	

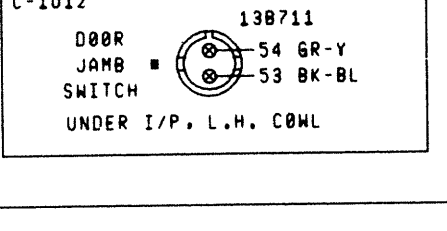
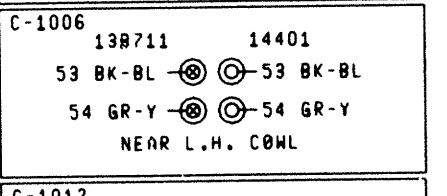
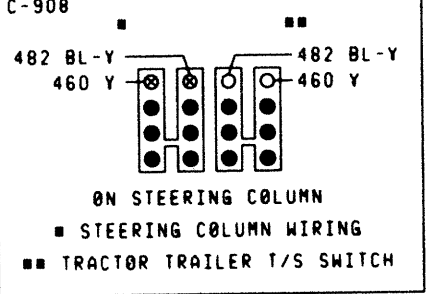
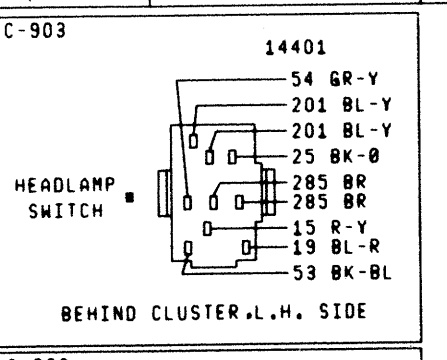
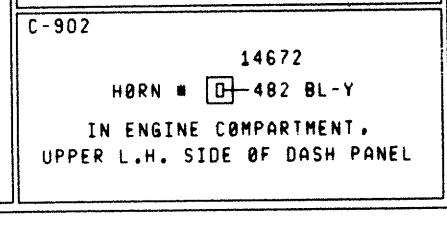
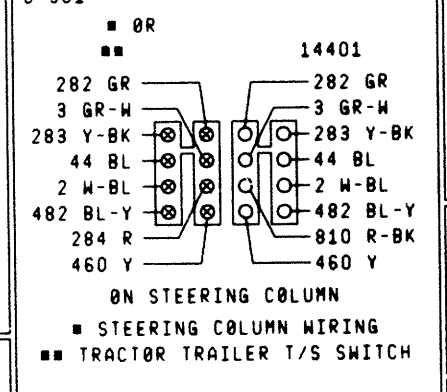
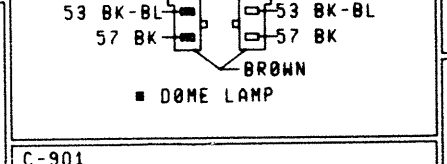
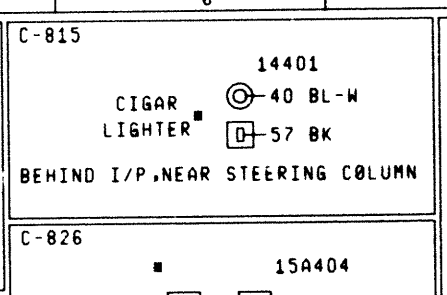
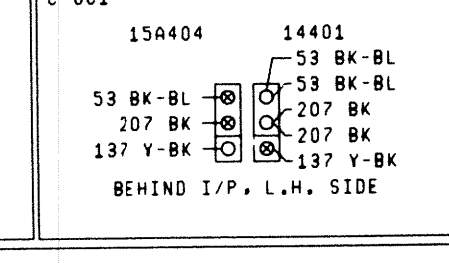
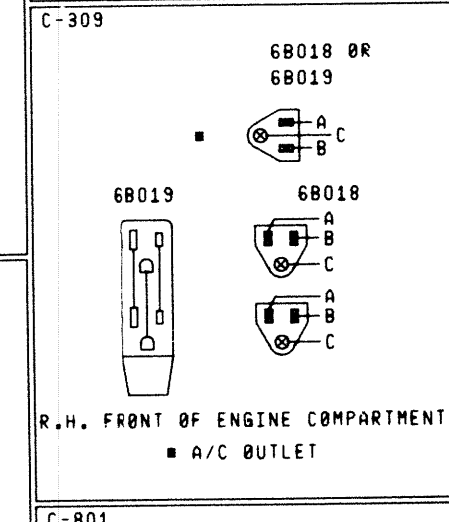
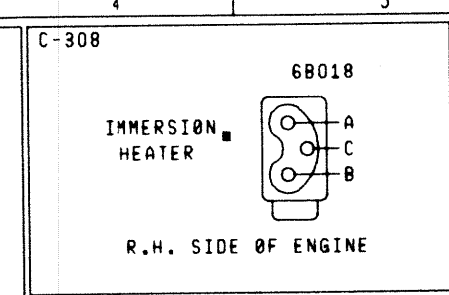
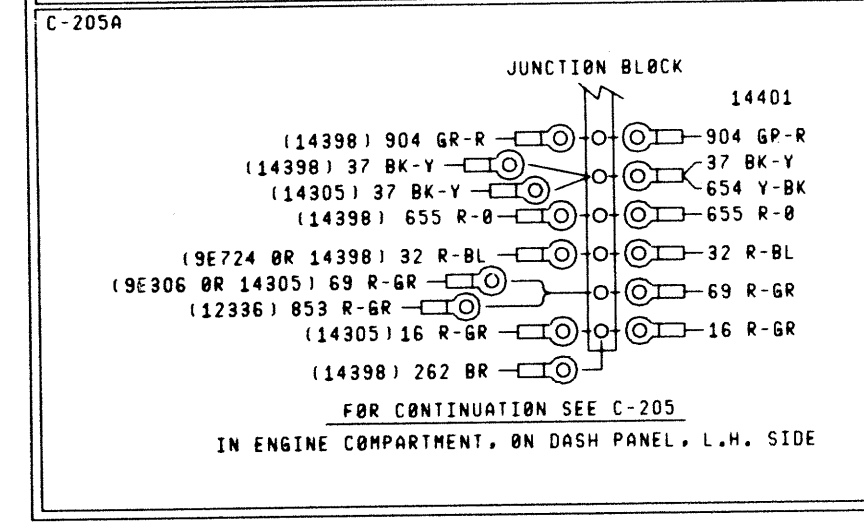
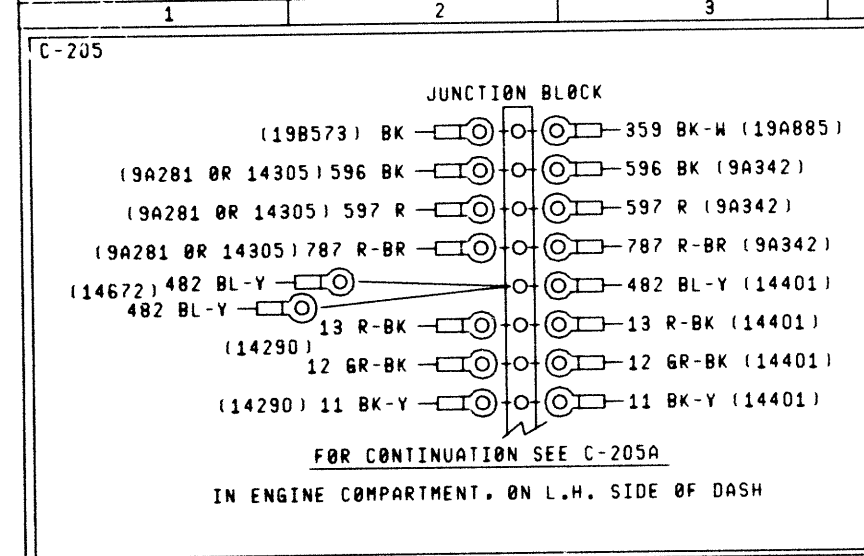
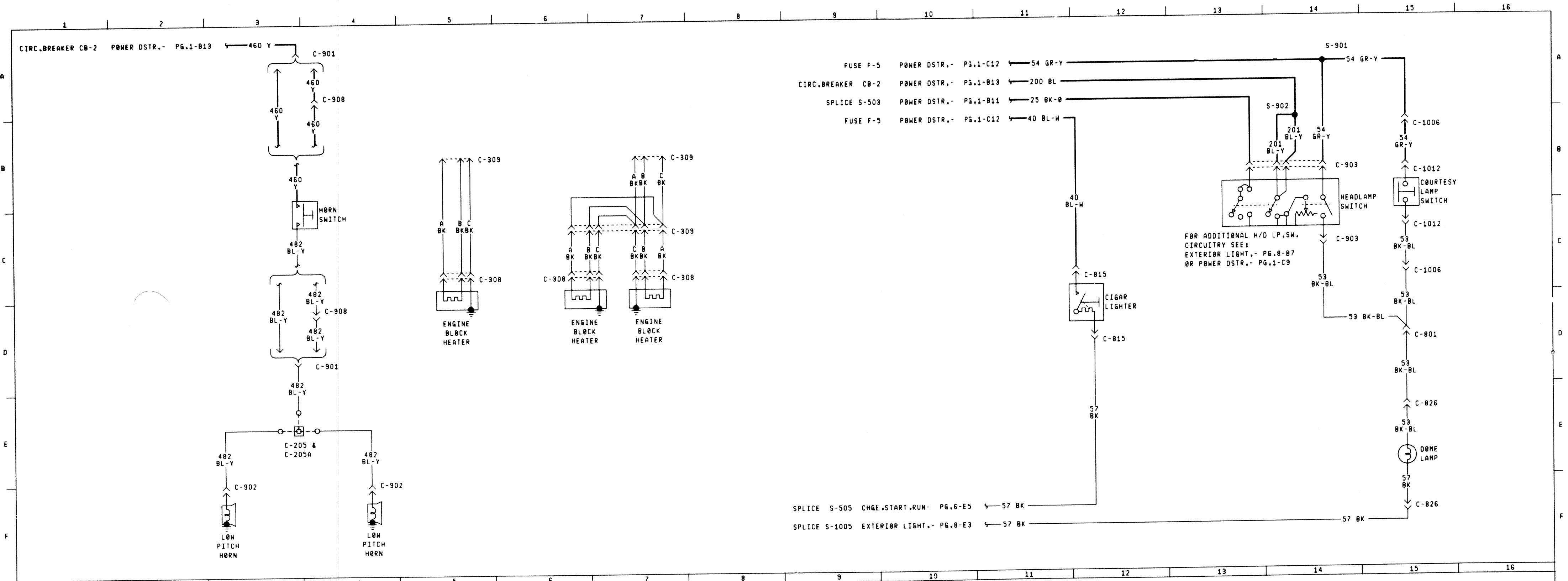

GROUND CODES	
SPICE CODES	
S-901	IN 14401, NEAR TAKEOUT TO THERMOSTAT SWITCH
S-902	IN 14401, NEAR TAKEOUT TO HEATER SWITCH
ELECTRICAL SYSTEMS 1976 L-SER (CITY DEL.)	
EFFECTIVE P.C.R.	HORN
SUPERSEDES	IMMERSION HEATER
DATE 10-30-75	PROTECTION AND CONVENIENCE
	TRPO ELECT INST MAN PAGE E6H-900-10
	SERVICE AND TRAINING MAN PAGE 10

HOW TO READ WIRING DIAGRAMS

COURSE 13001 • VOL. 68 S7 L2A

TABLE OF CONTENTS

Page

INTRODUCTION

A LOGICAL APPROACH TO ELECTRICAL DIAGNOSIS	1
Like reading a road map	2
How wires are numbered and color-coded	2
CIRCUIT — A COMPLETE ELECTRICAL PATH BETWEEN TWO POINTS	5
2-wire circuit	6
Single wire circuit	6
Ground connections	7
OPEN CIRCUITS	8
Shorts	9
Grounded circuit	9
Series and parallel open circuits	10
BREAKS IN PARALLEL CIRCUITS	11
Common points	14
Splices	15
Fuses and circuit breakers	17
Quick disconnects	18
Male and female elements	20
Types of quick disconnects	22
HINTS FOR TRACING WIRES THROUGH A DRAWING	23
Curve directions	23
Common points	24
Switches	25
Relays	26
Assemblies	28
Locating the assembly	29
Finding the wire	30
SUMMARY	31

The descriptions, testing procedures, and specifications in this handbook were in effect at the time the handbook was approved for printing. Ford Motor Company reserves the right to discontinue models at any time, or change specifications, design, or testing procedures without notice and without incurring obligations.

NATIONAL SERVICE OFFICE
FORD DIVISION



FIRST PRINTING — JANUARY, 1968

© 1968 FORD MOTOR COMPANY
DEARBORN, MICHIGAN

INTRODUCTION

The Why and Wherefore of Wiring Diagrams

To the uninformed, a wiring diagram — or a wiring assembly — looks like it might take a genius to figure out.

Not so — as you'll find out when you get better acquainted with these subjects.

There're as understandable and logical as a road map and road markers, when you're finding your way on a cross-country drive.

The ability to read a wiring diagram and relate it to a vehicle's wiring system is, of course, an essential part of a modern service technician's skill. And it's growing in relative importance, too, due to owner's increasing demands for the comforts and conveniences supplied by electrically-operated options and accessories. This opens up greater opportunities, for the forward-looking technician.

The Purpose of this Booklet . . .

. . . is to acquaint you with the systems by which electrical circuits are traced on vehicles. Specifically, it is designed to help you acquire the ability to make your own power checks, quickly and accurately.

Scope of the Booklet

Basically, this is a printed version of the film, "How to Read a Wiring Diagram." It is in no sense a manual of the shop methods by which electrical repairs are made.

It *can* be a helpful guide that can introduce you to the principles of wiring diagrams and vehicle wiring. As you gain experience in reading wiring diagrams, you'll accumulate your own know-how in this important skill. When it becomes "second nature" to you, these pages will have served their purpose — and yours.



To show how to read wiring diagrams — and to explain how they can be used to help you troubleshoot problems in the electrical system — is what this booklet is all about. Obviously, these are important subjects.

A LOGICAL APPROACH TO ELECTRICAL DIAGNOSIS



If a customer comes in because his headlights aren't working, you can't just make a snap decision. That's not the *professional way*.



Putting in a new sealed-beam unit *may* be the answer . . . but then again, *it may not*. Snap decisions are *out*. They're *not professional*.



When you go to a doctor, for example, he tries to find out what's *really* wrong with you. He looks beyond the aches and pains you feel, to see what's *causing* the trouble. We call this, *diagnosis*.

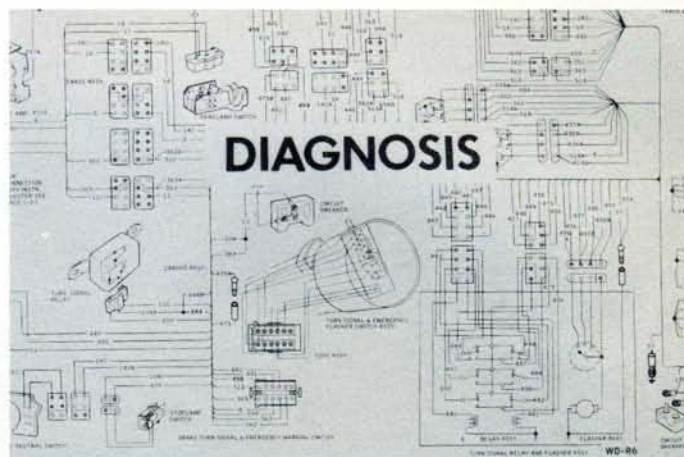

Tr
diagn
docto
troub

Buy Now

